

Please read and save these instructions. Read carefully before attempting to assemble, install, operate or maintain the product described. Protect yourself and others by observing all safety information. Failure to comply with instructions could result in personal injury and/or property damage! Retain instructions for future reference.

Ryton® & Stainless Steel Rotary Drum Pump

Description

Ryton & Stainless Steel Rotary Drum Pump can dispense and transfer some chemicals such as alkalines, detergents, mild acids, waxes, and water based chemicals. This self-priming pump is used for pumping applications on farms, construction sites, manufacturing plants and laboratories.

Specifications

Flow	8 GPM
Inlet	1 1/4" OD
Outlet	1" OD
Bung Adapter Mounting	2" NPT
Suction Tube	40 1/4" Polypropylene (PP)
(Length and Material)	
Packing Glandptfe & Viton
Wetted Partsptfe, Viton, Ryton, Polypropylene & 304SS
Max SSU	1,000 CPS
Max. Discharge Head.	3 ft. (1 PSI)
Max. Temp.	180° F

General Safety Information

▲ WARNING *It is the responsibility of the user to operate the pump in conformance with OSHA rules for dispensing liquids. Pump containers should be grounded when using with flammable liquids to avoid static electricity. Pump should be washed out before usage since processing lubricants could contaminate the fluids.*

1. When using a hand pump (especially when pumping flammable, combustible or hazardous liquids) follow all electrical and safety codes, as well as the United States Occupational Safety and Health Act (OSHA), most recent National Electrical Code (NEC), National Fire Protection, Inc. * (NFPA) Code 30 (Flammable and Combustible Code), NFPA 56A (Standard for use of Inhalation Anesthetics), NFPA 77 (Static Electricity), NFPA 78 (Lightning Protection Code), NFPA

80 (Standard for Fire Doors and Windows), NFPA 251 (Standard Method of fire Test of Building Construction), NFPA 704 (Identification of the Fire Hazards of Materials), other NFPA codes, local codes and ordinances, as needed in a particular application

2. Know the pump application, limitations, and potential hazards. The "WARNING" statements indicate potential hazardous conditions for the operator or equipment. TAKE NECESSARY STEPS TO PROTECT PERSONNEL AND EQUIPMENT.

NOTE: Pump should only be used with liquids compatible with pump component materials. Consult PUMP CHEMICAL COMPATIBILITY CHART and PUMP SPECIFICATIONS. Also, the chemical supplier should be consulted regarding any questions of chemical compatibility, proper and safe use and

handling of chemical. Misapplication of pump or use of noncompatible liquids will void warranty.

▲ WARNING *In order to properly use this product, familiarize yourself with this pump and also with the liquid (chemical, etc.) that is going to be pumped through the unit. Although this pump is suited for many liquids, it is NOT suitable for all liquids!*

(*) Any of the NFPA Codes can be obtained from : National Fire Protection Association, Inc., Batterymarch Park, Quincy, MA 0269, telephone 1-800-344-3555. Write or call for listing and prices.

3. Pumping hazardous, flammable, or combustible liquids should only be done in buildings, rooms, or areas suited for this purpose. (See NFPA 30, NFPA 78, NFPA 80, NFPA 251, NFPA 704, other suitable NFPA codes, OSHA, insurance companies, local codes and ordinances.)

Ryton® & Stainless Steel Rotary Drum Pump

General Safety Information (Continued)

▲WARNING *When filling cans, drums, etc. with combustible or flammable liquids, both container pumping from and container pumping to, should be bonded and grounded to dissipate possible accumulations of static electricity, and minimize sparks caused by static electricity (refer to NFPA 77 for specific details).*

Removal of outer garments in work areas where there may be flammable or explosive liquids, which are ignitable with low electrical energy, can be fatal and/or cause property damage (refer to NFPA 56A, and NFPA 77, for further details).

4 The "WARNING" and instructions for gasoline below pertain not only to gasoline, but to any flammable, combustible or hazardous fluid.

▲WARNING *Gasoline is a highly flammable fuel. The improper use, handling or storage of gasoline can be dangerous. Prevent accidents by following these safety rules:*

- Use gasoline only as a fuel, never as a cleaning fluid.
- Use only an approved container to hold or store gasoline. Never store gasoline in familiar containers such as milk containers or soda pop bottles.
- Store gasoline in a cool location, out of the reach of children. Never store gasoline near heat or an open flame.
- Provide a fire extinguisher nearby when working with gasoline. Be sure extinguisher is in operating condition - check the pressure gauge or indicator. Be familiar with its proper use. Consult local fire department for the correct type of extinguisher for your application. Extinguishers rated

ABC by the National Fire Protection Association are appropriate for most applications.

- Provide positive shut-off valves on all permanent fuel supplies. Fuel lines must be of steel piping, adequately secured, and free from leaks.
 - Provide adequate ventilation, and clean up any spills when handling or pumping flammable liquids.
- POSITIVELY NO SMOKING!
 - Do not use torches or apply fire or flame to this pump for any reason.
 - Secure the discharge line before starting the pump. An unsecured discharge line will slip, possibly causing personal injury and/or property damage.
 - Do not over tighten nonmetallic threaded fittings. One full turn past hand tight is usually enough to prevent leakage. ptfе sealant tape should be used on all threaded joints, including the spout.
 - Check hoses for weak or worn condition before each use, making certain that all connections are secure.
 - Periodically inspect pump and system components. Perform routine maintenance as required.
 - Drain all liquids from the system before servicing.

▲WARNING *Any pump used to transfer flammable liquids must be stored in a well ventilated area after use.*

11. Personal Safety

- Wear safety glasses at all times when working with pump.
- Wear a face shield, proper apparel and suitable respiratory equipment, when pumping hazardous chemicals.

- Keep work area clean, uncluttered, and properly lighted, replace all unused tools and equipment.
- Keep visitors at a safe distance from the work area.
- Make workshop childproof, with padlocks, master switches, and by removing starter keys.

▲WARNING *Failure to follow all general safety information can result in a fatality, personal injury and/or property damage!*

Assembly & Installation

- Screw bung adapter (Ref. No. 14) into drum with threaded end down.
- Screw spout (Ref. No.1) into casing (Ref. No. 3). Use ptfе sealant tape provided. Do not over tighten.
- Screw suction tube (Ref. No. 22) into tail pipe (Ref. No. 20) and suction tube (Ref. No. 21). Use ptfе sealant tape provided.
- Screw suction tube assembly into casing (Ref. No. 3). Use ptfе sealant tape provided. Do not overtighten.
- Insert handle shaft (Ref. No. 17) through handle (Ref. No. 12). Thread hex nut (Ref. No. 18) onto handle shaft until handle rotates freely.
- Screw handle assembly into crank arm (Ref. No. 11). Prevent handle shaft from turning, then tighten hex nut against crank arm. Insert crank arm assembly onto motor shaft and tighten in the rotor shaft.
- Insert pump assembly into drum through the bung adapter and tighten the thumb screw (Ref. No. 15) by hand. Do not use a wrench or tool to tighten the thumb screw.

Model 3004

Operation

1. Rotate handle clockwise several times. If unit does not pick up prime in a few turns, pour some fluid into pump discharge to aid priming
2. For siphoning, set handle straight down.
3. To stop siphoning, rotate handle 1/4 turn.

4. After using pump, set handle straight down. Liquid will drain back to container.
5. If pump is removed from drum, rinse thoroughly in liquid that is compatible with both the pump and fluid. For questions about chemical compatibility contact your chemical supplier.

Maintenance

IMPORTANT: Periodically inspect the pump assembly and suction tubes for weak or worn condition. Make certain that all connections and fasteners are tight and secure. Perform routine maintenance as required.

90 Day Limited Warranty

Figure 1 — Replacement Parts Illustration

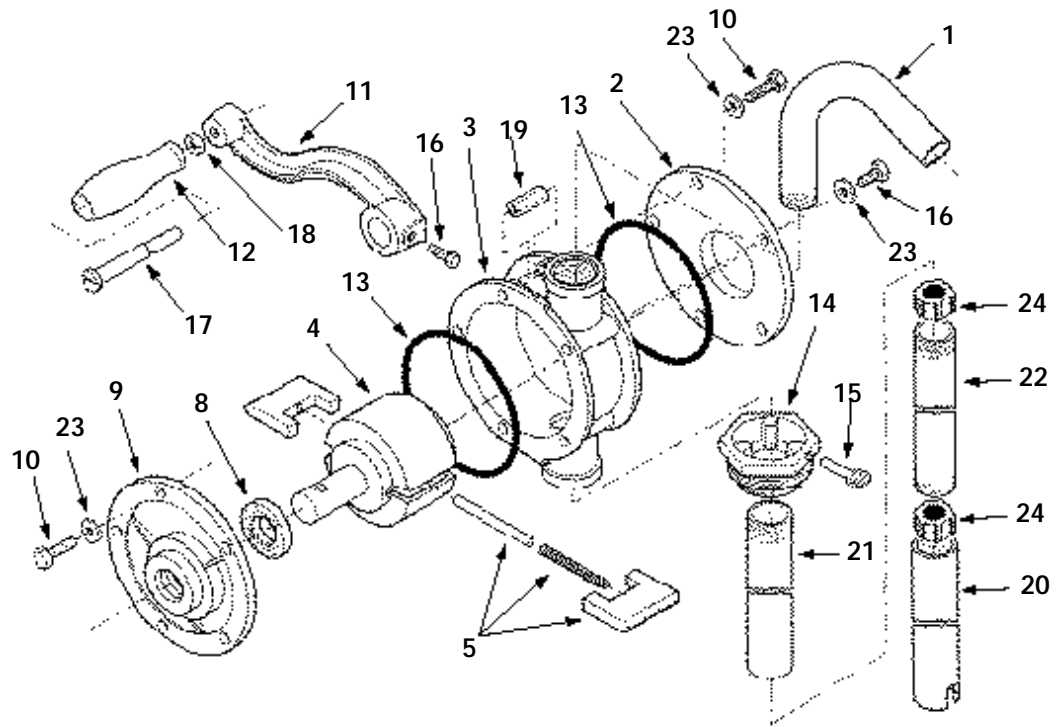

Figure 1 — Replacement Parts Illustration

Replacement Parts List

Reference Number	Description	Part Numbers for Model 3004	Quantity
1	Discharge spout	3004-01	1
2	Rear Cover	3004-02	1
3	Casing	3004-03	1
4	Rotor assembly	3004-04	1
5	Vane kit (2 Vanes, 1 spring, 1rod)	3004-RKT	1
8	Lip Seal	3004-08	1
9	Front Cover	3004-09	1
10	5/16-18 x 1" Cap Screw	3004-10	4
11	Crank Arm	3004-11	1
12	Handle	3004-12	1
13	O-Ring	3004-65	2
14	Bung Adapter	3004-14	1
15	Thumb screw	3004-15	1
16	5/16-18 x 3/4" Cap Screw	3004-16	7
17	Handle shaft	3004-17	1
18	3/8-16" Hex nut	3004-18	1
19	Hex Bridge Sleeve	3004-19	2
20	Bottom suction tube	3004-13	1
21	Top suction tube	3004-22	1
22	Middle suction tube	3004-23	1
23	5/16" Flat Washer	3004-21	10
24	Pipe connectors	N/A	N/A

Warranty

Action Pump™ pumps covered in this manual are warranted for a period of 90 days from date of purchase against defects in workmanship or materials under normal use. These pumps are not warranted against misuse or for the pumping of gasoline or highly flammable liquids containing strong solvents.

Under no circumstances shall the manufacturer be liable for any liability, loss or damage, direct, incidental, accidental or consequential arising out of the use of, or inability to use the pumps covered in this manual.

Before using the pumps covered in this manual, the user shall determine the suitability of the pump for its intended use and any user assumes all risks and liability whatsoever in connection therewith.

If any doubt exists about the whether the pumps covered in this manual can be used safely with a particular product, clarification should be sought from the distributor of the pumps covered in this manual.