

Please read and save these instructions. Read carefully before attempting to assemble, install, operate or maintain the product described. Protect yourself and others by observing all safety information. Failure to comply with instructions could result in personal injury and/or property damage! Retain instructions for future reference.

Action Air-Driven Drum Pump

Description

Action drum pumps are air-driven and self-priming. They are designed to transfer clean, non-abrasive, flammable liquids that are compatible with pump materials. The motor is isolated from liquid by a mechanical seal made of PTFE. Model ACT-12NSS has an outer column and inner shaft made of 316SS.

0 ft.	5 ft.	GMP† Total Head (in Feet)		20 ft.	Max. Head*	Max. Viscosity
		10 ft.	15 ft.			
17	13	9	5	1	20.7 ft.	500 CPS

(†) Based on water at 72° F.

(*) Calculate equivalent PSI by dividing head (in feet) by 2.31.

Specifications

Model ACT-12NSS	
Motor	Rotary vane air motor (4Z411)
Maximum air flow	.27 CFM
Maximum inlet air pressure	.80 PSI
Maximum torque	6.5 in/lbs.
Maximum oper. temp.	150° F
Horsepower	1/2 HP
Speed	6000 rpm
Seals	PTFE
Discharge hose	.5 ft., 1 in. I.D.

Performance

Power	0 ft.	5 ft.	10 ft.	15 ft.	20 ft.	Max. Head*	Equiv. PSI
80 PSI Air	12	9	6	3	Ñ	17.8 ft.	7.7
60 PSI Air	10	7	4	1	Ñ	15.7 ft.	6.8

(†) Based on water at 72° F.

(*) Calculate equivalent PSI by dividing total head by 2.31.

Action Air-Driven Drum Pumps

General Safety Information

▲ WARNING *Pump should only be used with liquids compatible with pump component materials failure to follow this warning can result in personal injury and/or property damage.*

1. Know the pump application, limitations, and potential hazards.
2. Provide adequate protection and guarding around moving parts.
3. Release all pressure within the system before servicing any component.
4. Drain all liquids from the system before servicing.
5. Secure the discharge line before starting the pump. An unsecured discharge line will whip, possibly causing personal injury and/or property damage.
6. Check hoses for weak or worn condition before each use, making certain that all connections are secure.
7. Periodically inspect pump and system components. Perform routine maintenance as required. (see Maintenance section).
8. Provide a means of pressure relief for pumps whose discharge line can be shut off or obstructed.
9. **Personal Safety**
 - a. Wear safety glasses at all times when working with pump.
 - b. Wear a face shield, proper apparel when pumping hazardous chemicals.
10. Follow all safety codes, as well as the most recent United States National Electrical Code (NEC) and the Occupational Safety and Health Act (OSHA).
11. DO NOT drive this air motor with a combustible gas.

12. Always disconnect air source and release system pressure when working on air motor unit, or any component in the system.
13. DO NOT exceed pressure limits for any component in the system.
14. Check air lines and fittings for weak or worn condition before each use.
15. Maximum input pressure for air motor is 80 PSI.
16. DO NOT operate air motor when there is no load on its shaft.

Installation/Operation

1. Install a filter, regulator and lubricator in the air line, as close as practical to the air motor. The lubricator should be the closest to the air motor of these three accessories. Adjust the lubricator to feed oil at one drop for every 50-75 CFM of air going through the air motor. Make sure that the air line piping is clean so that metal chips, rust scale, old pipe dope, etc. do not get into the air motor.

▲ WARNING *Do not use filter/regulators or any other accessories with polycarbonate plastic parts with this drum pump when the air is supplied by a compressor lubricated with synthetic oil or oils containing phosphate esters or chlorinated hydro-carbons. These oils, as well as some chemicals such as carbon tetrachloride, trichorethylene, acetone, paint thinner, cleaning fluids and other solvents can carry over into the air distribution system and possibly rupture the bowls, domes, etc. In all cases where these chemicals and oils are present, components with metal parts such as the Dayton Model 4Z347 filter/regulator and the Dayton Model 4Z346 mist lubricator should be used. These accessories must always be isolated from the drum pump when used in an explosive atmosphere.*

2. Place the pump into the liquid to be pumped.

▲ CAUTION *Do not pump liquids containing metal chips or shavings. Never operate the pump dry. These will damage the pump.*

3. Attach the pump to the drum with a bung adapter supplied.
4. Secure the discharge line of the pump to keep it from lashing about.

NOTE: Pump will drain down when it is shut off

Maintenance

▲ WARNING *Disconnect air supply before servicing.*

1. After each use, flush the pump with water or a suitable solvent.

▲ CAUTION *Do not stand the pump on its shaft.*

2. Store the pump in a clean, dry area; the preferred method of storage is hanging.
3. Periodically inspect the pump for excessive wear, or damage.
4. Motor bearing never needs to be lubricated, replace when necessary.
5. Replace any worn or damaged parts immediately.

LUBRICATION OF AIR MOTOR

Use detergent SAE #10 automotive engine oil. For proper operation and maximum service life an automatic air line lubricator must be installed in the air line just ahead of the inlet port on the air motor. The lubrication should be adjusted to feed one drop of oil for every 50-75 CFM of air flowing through the motor. Lubrication is necessary for all internal moving parts and for rust prevention.

**LUBRICATION OF AIR MOTOR
(CONTINUED)**

Excessive moisture in the air line can cause rust formation in the motor and may also cause ice to form in the muffler, due to the expansion of the compressed air as it drives the motor. The moisture problem can be corrected by installing an aftercooler between the compressor and the air receiver.

SERVICING

If the motor is sluggish or inefficient, try flushing it with solvent in well ventilated areas. To flush the motor, disconnect the air line and muffler and add several teaspoons of solvent directly into the motor.

Recommended commercial solvents for air motors and lubricated pumps are: DEM-KOTE 2X726, Loctite Safety Solvent, Inhibisol Safety Solvent, Dow Chemical Chlorothane, or any nontoxic, nonflammable industrial cleaning solvent.

CAUTION *Do not allow any solvent to get into the lubricator.*

Rotate the shaft by hand in both directions for a few minutes, reconnect the air line, and slowly apply pressure until there is no trace of solvent in exhaust air. (Keep your face away from exhaust air.) Relubricate the motor with a squirt of oil in the chamber.

If the vanes need replacing, or if foreign materials are present in the motor chamber, have an experienced mechanic remove the end plate opposite the drive shaft end. (Do not pry the plate off with a screwdriver. It will dent the surface of the plate and body, causing leaks. Use a puller tool, which will remove the end plate while maintaining the position of the shaft.) Install new vanes so that the vane edges having the corners cut on angle (or the notched edges of reversible vanes) face the bottom of the vane slots.

Troubleshooting Chart

Symptom	Possible Cause(s)	Corrective Action
Pump does not prime	<ol style="list-style-type: none"> 1. Clogged impeller or augers 2. Clogged discharge port/hose 3. Broken shaft coupling 4. Worn or damaged shaft seal 	<ol style="list-style-type: none"> 1. Clean impeller and augers 2. Clean discharge port/hose 3. Replace shaft coupling 4. Replace shaft seal
Insufficient flow	<ol style="list-style-type: none"> 1. Possible causes for "Pump does not prime" (above) 2. Pinched discharge hose 3. Pumped liquid is too viscous 	<ol style="list-style-type: none"> 1. Check and repair as is necessary 2. Unpinch discharge hose 3. Use only for liquids with viscosity within range of pump (500 CPS maximum)

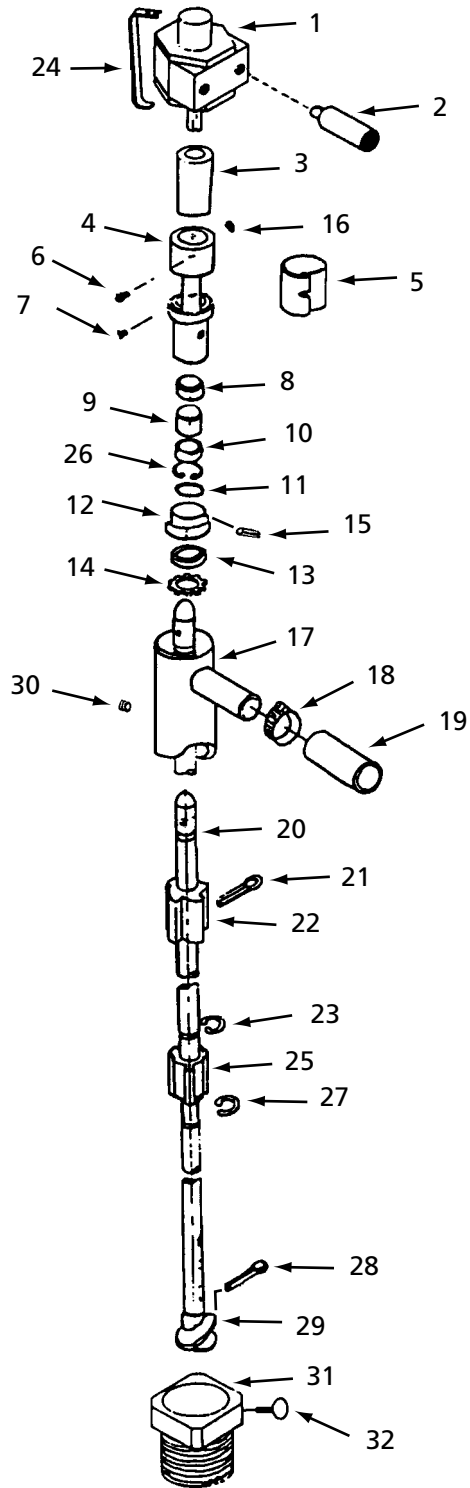

Figure 1 — Replacement Parts Illustration for Model ACT-12NSS

Replacement Parts List

Reference Number	Description	Part Number	Quantity
1	Air Motor (includes #2)	4Z411	1
2	Muffler (VN04335)	AF350	1
3	Motor Coupling	66896	1
4	Handle/Support Assembly	67215	1
5	Cover Plate	67216	1
6	Retaining Screws	67219	2
7	Cover Screw	67217	1
8	Bearing	66108	1
9	Spacer	66189	1
10	Bearing	66108	1
11	"O" Ring	66111	1
12	End Cap	66912	1
13	Seal	66413	1
14	Washer	66555	1
15	Roll Pin	66005	1
16	Coupling Set Screw	66016	2
17	Outer Column 316 SS	66717	1
18	Hose Clamp	1P416	1
19	5 ft. Hose EPDM	66119	1
20	Inner Shaft	66120	1
21	Cotter Pin	66921	1
22	PTFE Impeller	66722	1
23	"C" Ring Retainer	66123	3
24	Handle	67218	1
25	Spacers (PTFE)	66825	3
26	Retaining Ring	66130	1
27	"C" Ring Retainer	66123	3
28	Cotter Pin	66921	1
29	PTFE Compressor Auger	66629	1
30	Tube Set Screw	66017	2
31	Bung Adapter	65000	1
32	Thumb Screw	1650-19	1

