

Contents

I. Electrical Control of Inverter Air Conditioner	2
1. Main compositions of the electrical control of inverter air conditioner	2
2. Wiring of Inverter AC Unit	3
3. Current Flow	4
4. Computer Control Function Flow Chart for Inverter AC Unit	5
5. Protection and Fault Codes	5
II. Troubleshooting	8
1. According to the fault code	8
(1) Display E1 or E2:	8
(2) Display E6	9
(3) Display E3, E7, E8	10
(4) Display E4	11
(5) Display EC	13
(6) Display EP	14
(7) Display EA	16
(8) Display EU	17
(9) Display E9 (Firstly display P0 or P9, then change to E9)	18
(10) Display E0、E5	20
(11) Display EE	22
(12) Display P0	23
(13) Display P1	24
(14) Display P2	24
(15) Display P4	25
(16) Display P5	25
(17) Display P6	26
(18) Display P7	27
(19) Display P8	27
(20) Display P9	28
2. Other faults	29
1) The indoor unit works normally but the outdoor unit does not work.	29
2) The outdoor unit is stopped when the air conditioner has run for a period of time	29
3) The air conditioner is tripped when it is started.	30
4) The complete unit does not work	30
Appendix 1	31
Appendix 2	34
Appendix 3	36
Cautions on Replacement of PCB Boards	37

I. Electrical Control of Inverter Air Conditioner

1. Main compositions of the electrical control of inverter air conditioner

The electrical control of inverter air conditioner is divided into indoor control system and outdoor control system.

Relative to the fixed-speed air conditioner, the indoor control system is added with one communication circuit, but removed of the control circuits for compressor, 4-way valve and outdoor fan. The other circuits are basically the same.

The outdoor circuit is generally divided into three parts, i.e. outdoor power source board, Power Factor Correction (PFC) board and Intelligent Power Module (IPM). The details are as follows:

IPM board

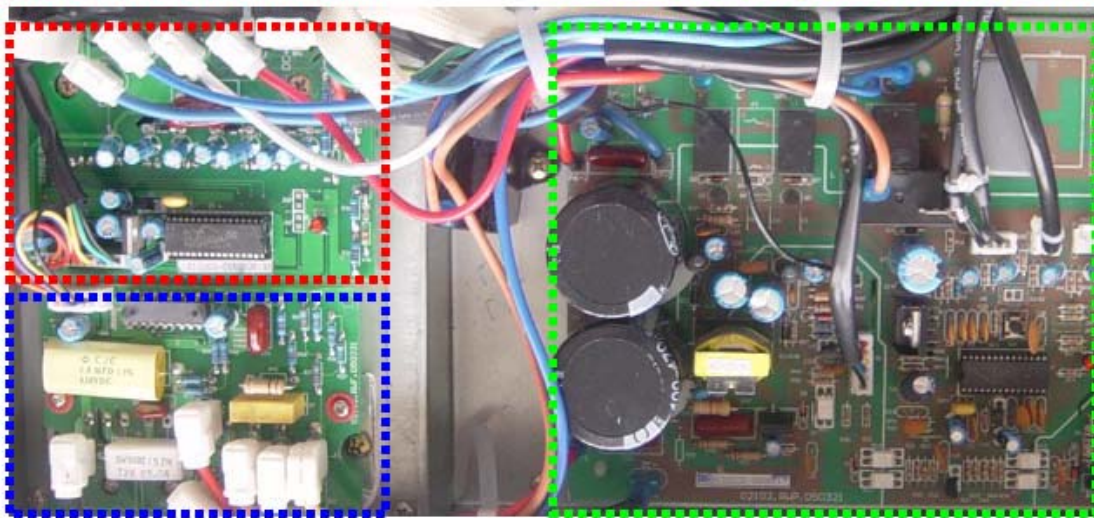

PFC board

Outdoor power source board

TCL Inverter Air Conditioner Model 1 – 1.5P has been developed for four generations.

The 1st generation (V1) applies 120° square wave control plan and the all PFC plan is used for power treatment.

The 2nd generation (V2) remains to apply 120° square wave control plan, but the partial PFC plan is used for power treatment. This product is never put into batch production.

The 3rd generation (V3) applies 180° sine wave plan and partial PFC plan. This model is also few.

The 4th generation (V4) remains to apply 180° sine wave plan (including 2P unit), where only significant adjustment is made to the function architecture. That is, the indoor control plan applied for the 1st and 2nd generation is changed to outdoor control (For details on the function distribution, please refer to the Control Function Chart below).

The 5th generation(V5), the function is same as V4, but the Power source board, PFC board and IPM board have already integrated onto one board (All-In-One) for easily installation and

repairing.

The products 2P and higher are mainly developed for two generations.

The 1st generation (VP1) applies NEC 180° sine wave plan and indoor control.

The 2nd generation (VP2) applies TI DSP 180° sine wave plan and outdoor control. (Exclusive of 2P unit).

There are derivative models, e.g. full DC inverter unit, inverter floor-standing unit and LC plan. See Appendix 1 for details.

2. Wiring of Inverter AC Unit

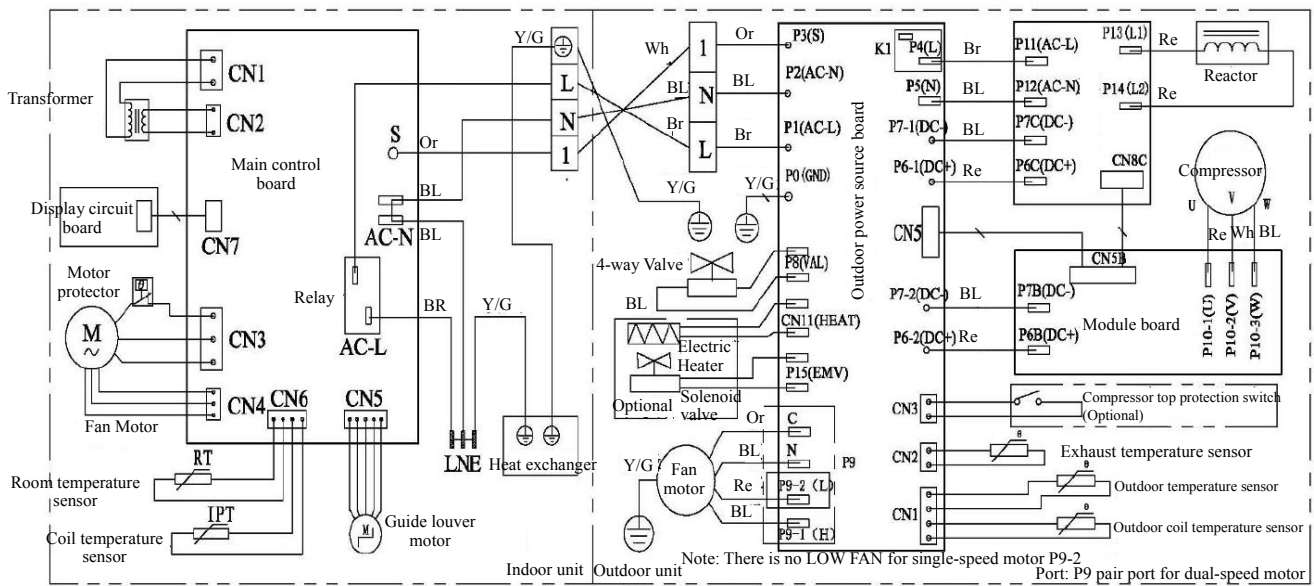

3. Current Flow

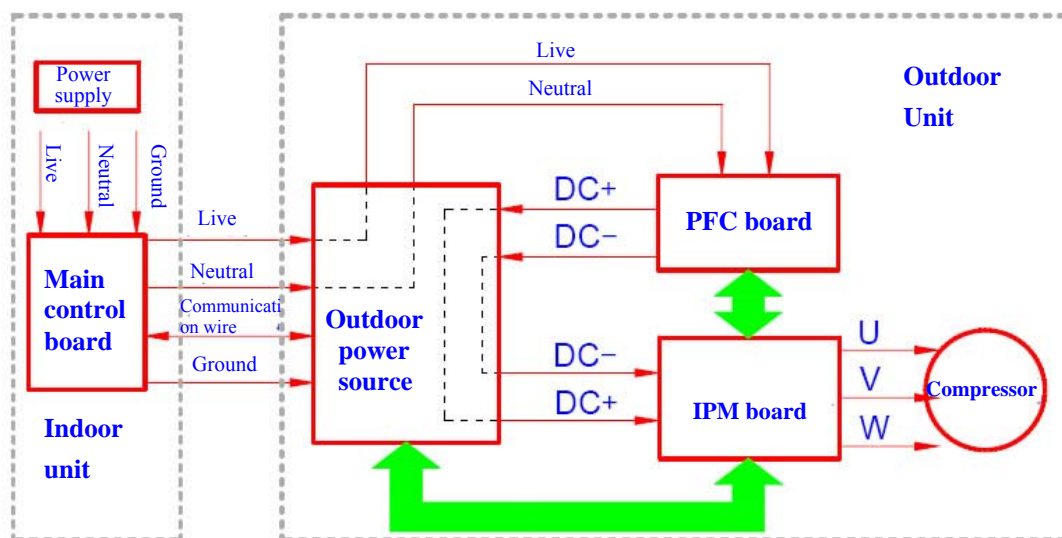

4. Computer Control Function Flow Chart for Inverter AC Unit

1) Outdoor control plan

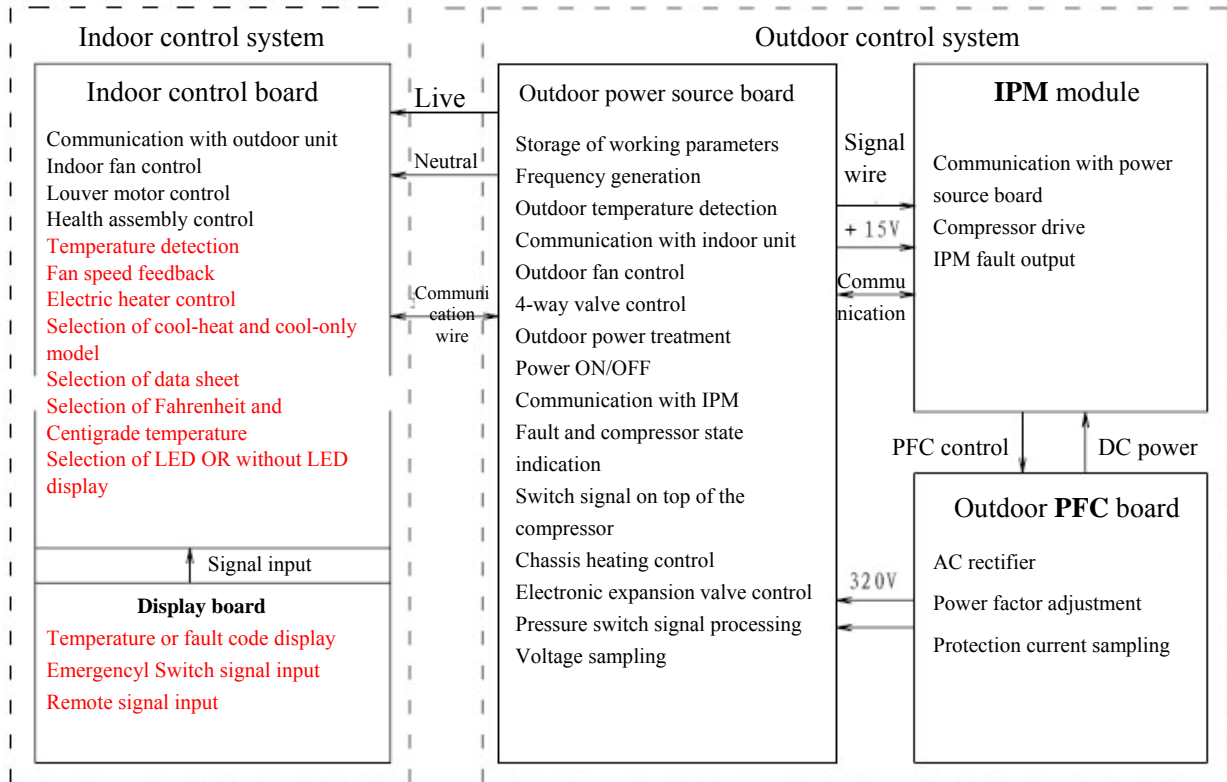

2) Indoor control plan

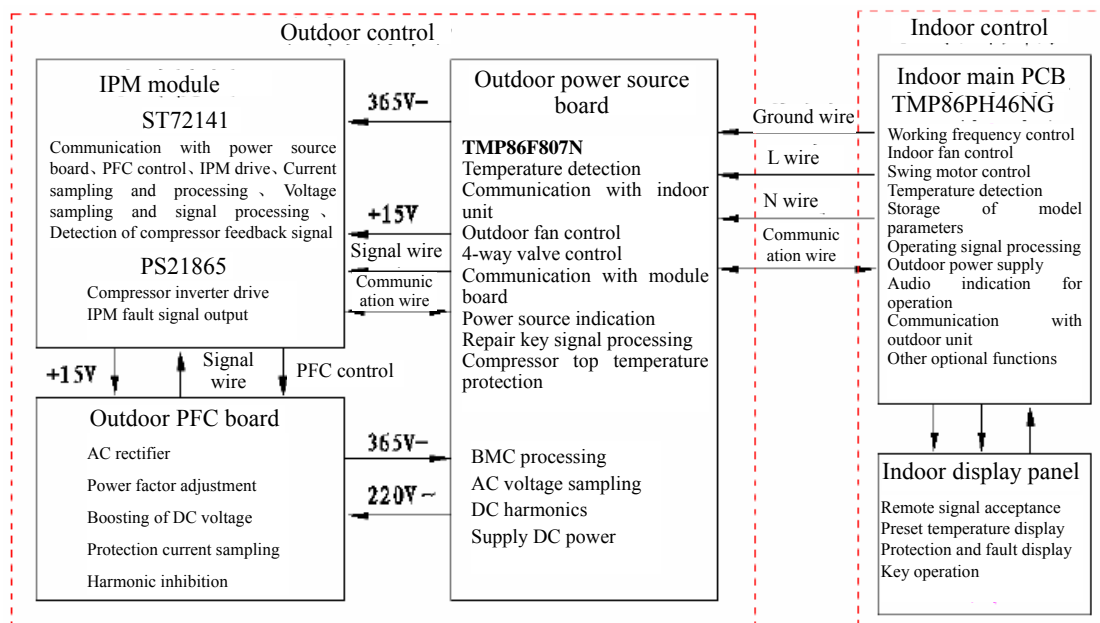

5. Protection and Fault Codes

Fault Code

Fault Type	Function Indicator (flash)	Digital LED display
Indoor/outdoor communication fault	RUN & TIMER: Blink	E0
outdoor communication fault	RUN & TIMER: Blink	EC
Room temperature sensor (IRT)	RUN-1/8 sec.	E1
Indoor pipe (coil) temperature sensor (IPT)	RUN-2/8 sec.	E2
Outdoor pipe (coil) temperature sensor (OPT)	RUN-3/8 sec.	E3
System abnormal	RUN-4/8 sec.	E4
Model configuration wrong	RUN-5/8 sec.	E5
Indoor fan motor fault	RUN-6/8 sec.	E6
Outdoor temperature sensor	RUN-7/8 sec.	E7
Exhaust temperature sensor	RUN-8/8 sec.	E8
Intelligent power module of drive and module fault	RUN-9/8 sec.	E9
Outdoor fan motor fault (DC Motor)	RUN-10/8 sec.	EF
Current sensor fault	RUN-11/8 sec.	EA
EEPROM fault	RUN-12/8 sec.	EE
Temperature switch fault (on top of the compressor)	RUN-13/8 sec.	EP
Voltage sensor fault	RUN-14/8 sec.	EU
Intake temperature sensor	RUN-15/8 sec.	EH

Protection Code

Protection Type	Function Indicator (flash)	Digital LED display
Overvoltage / undervoltage protection	RUN: Blink; TIMER: 1 blink /8 sec	P1
Overcurrent protection	RUN: Blink; TIMER: 2 blink /8 sec	P2
Exhaust overtemperature protection	RUN: Blink; TIMER: 4 blink /8 sec	P4
Subcooling protection under cooling mode	RUN: Bright; TIMER: 5 blink /8 sec	P5
Overheating protection under cooling mode	RUN: Bright; TIMER: 6 blink /8 sec	P6
Overheating protection under heating mode	RUN: Bright; TIMER: 7 blink /8 sec	P7
Outdoor overtemperature / undertemperature protection	RUN: Bright; TIMER: 8 blink /8 sec	P8
Drive protection (software control)	RUN: Blink; TIMER: 9 blink /8 sec	P9
Module protection (hardware control)	RUN: Blink; TIMER: 10 blink /8 sec	P0

Display on outdoor power source board: The indicator alerts the fault in a cycle as such that it is bright for 0.5 seconds, dark for 0.5 seconds, blinks “n” times and then dark for 3 seconds.

Blink times(n)	Fault Message	Blink times(n)	Fault Message
1	IPM protection	18	Short-circuit / open-circuit fault of intake temperature sensor
2	Oversvoltage / undervoltage	19	Outdoor EEPROM fault
3	Overcurrent	20	Outdoor fan motor protection
4	Exhaust overtemperature protection	21	Indoor fan motor protection
5	Outdoor coil overtemperature protection		
6	Drive fault and protection (V1, VP1)	23	System in shortage of Freon
7	Communication fault with indoor unit	24	Model configuration wrong
8	Compressor overheat fault (compressor top switch)	25	Indoor sensor fault
9	Short-circuit / open-circuit fault of outdoor temperature sensor	26	Indoor coil sensor fault
10	Short circuit / open-circuit fault of outdoor heat exchanger temperature sensor	27	Indoor EEPROM fault
11	Short-circuit / open-circuit fault of exhaust temperature sensor	28	Indoor fan motor fault
12	Voltage sensor fault	30	drive fault (V4、VP2)
13	Current sensor fault	31	Outdoor environmental overtemperature / undertemperature protection
14	IPM fault	32	Indoor coil deforst prevention
15	communication fault between power source board and intelligent power module	33	Indoor coil overheating protection
16	No feedback from DC fan motor(outdoor unit)		
17	Defrost state		

Display on V5 All-in-one board

Blink Counts	Fault Message	Blink Counts	Fault Message
1	IPM fault	2	Short-circuit / open-circuit fault of outdoor temperature sensor
3	Outdoor coil sensor fault	4	Absorption temperature sensor fault
5	Exhaust temperature sensor fault	6	Current sensor fault
7	Compressor drive fault	8	Compressor drive protection
9	Outdoor overheat protection	10	IPM protection
11	AC overcurrent protection	12	Exhaust Temperature Protection
13	Compressor top temperature protection	14	Exhaust Overtemperature Protection
15	Voltage protection	16	Exhaust underpressure protection
17	Exhaust Overpressure Protection	18	Indoor antifreeze protection
19	Indoor overheat protection	20	Indoor / outdoor communication fault
21	Outdoor EEPROM fault	22	Outdoor ambient overtemperature protection
23	Outdoor DC fan fault	24	Outdoor coil overheat protection
25	Model configuration wrong	26	Indoor fan fault
27	Reserved	28	Reserved
29	Reserved	30	Reserved

V5 All-in-one board

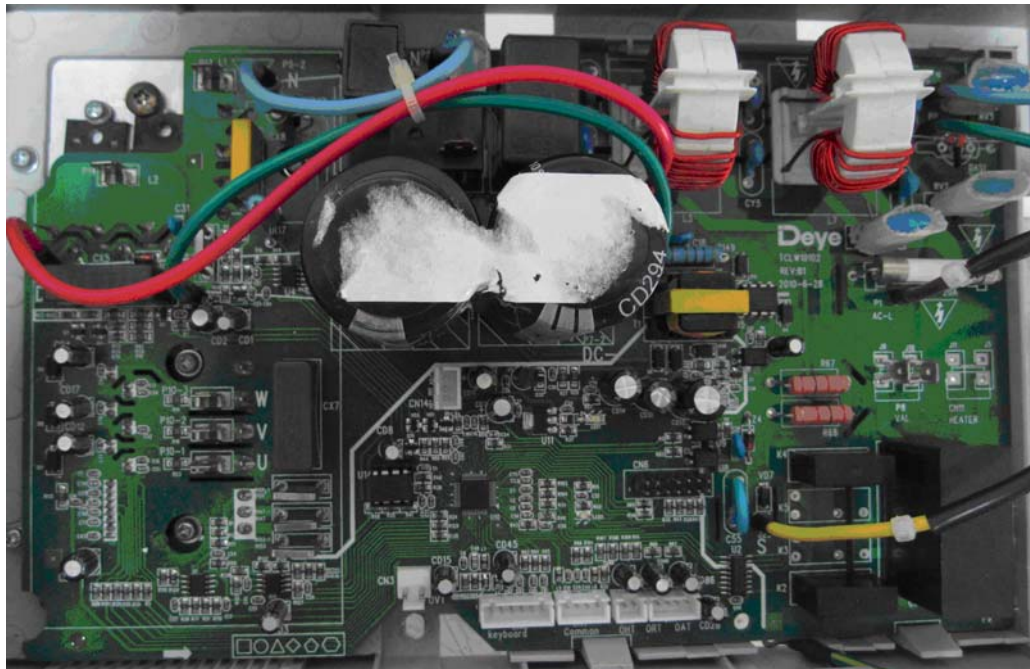

II. Troubleshooting

1. According to the fault code

(1) Display E1 or E2:

Symptom		Display E1 or E2	
Cause		Room temperature sensor (IRT) and Indoor pipe (coil) temperature sensor (IPT) fault	
S/N	Inspections	How to Solve	Remarks
1	Contact between indoor temperature sensor CN6 (RT, IPT) and slot	Insert again if loose.	Photo 1
2	Measure the resistance on the two ends of indoor temperature sensor: (25°C/ 5KΩ). For other resistance, please refer to the Temperature – Resistance Sheet (Appendix 1).	Replace the temperature sensor if the resistance is incurred to drift, open or short circuiting.	Photo 2
3	If the above testing is normal	Replace the indoor control board	

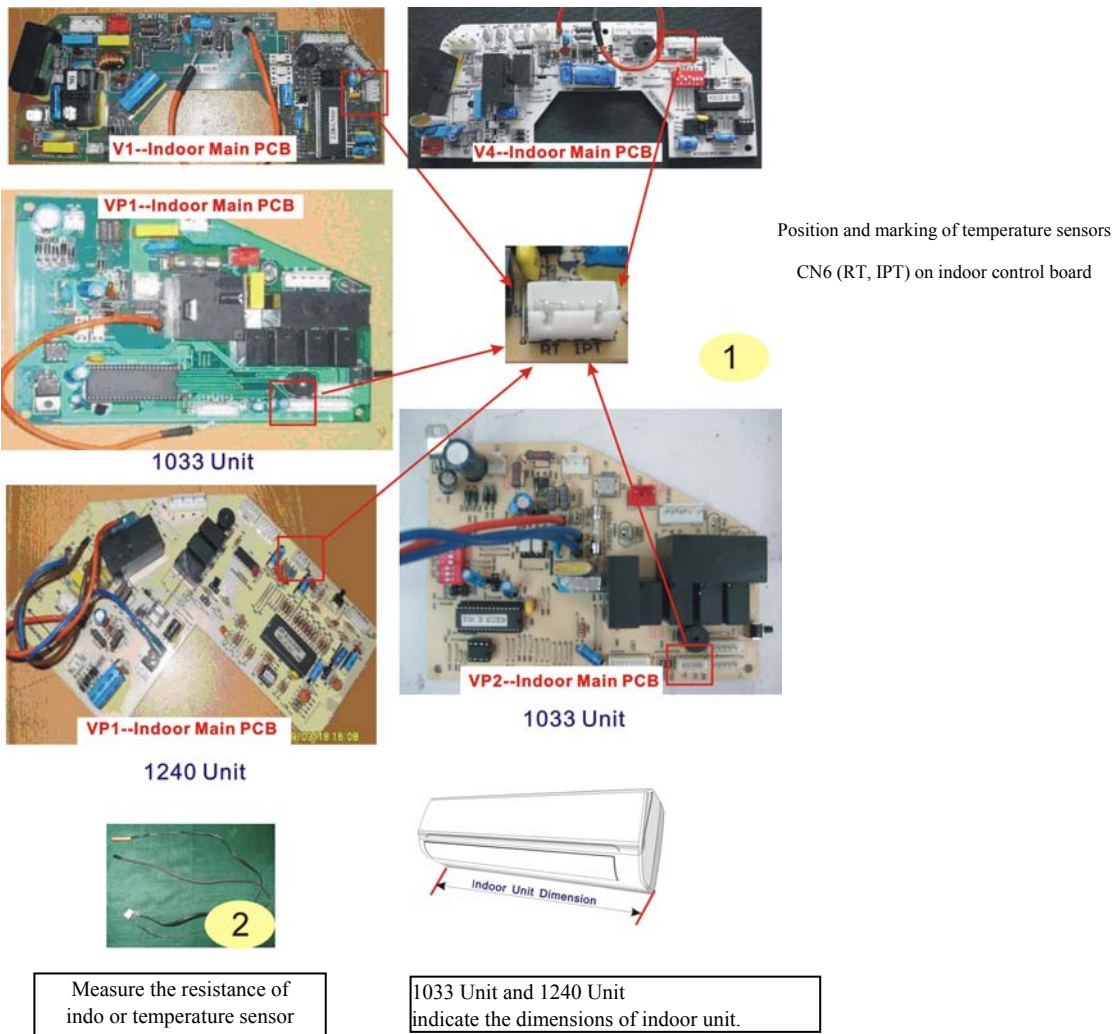

(2) Display E6

Symptom		Display E6	
Cause		Indoor fan motor fault	
S/N	Inspections	How to Solve	Remarks
1	Check the indoor cross-flow fan blade	If the fan does not run, readjust the fan position until it can run smoothly.	
2	If the motor insert (CN3, CN4) on indoor main PCB is in good contact with the slot	Insert again if loose.	Red-line part
3	Startup capacitance value	Capacitance incorrect. Replace with a new capacitor.	Yellow-line part
4	The above inspections are normal	Replace the indoor main PCB	



(3) Display E3, E7, E8

Symptom		Display E3, E7, E8	
Cause		Outdoor pipe (coil) temperature sensor and outdoor temperature sensor and exhaust temperature sensor fault	
S/N	Inspections	How to Solve	Remarks
1	If the temperature sensor on outdoor power source board is in good contact with the slot (CN1, CN2)	Insert again if loose.	Photo 3
2	Measure the resistance on the two ends of outdoor temperature sensor: Resistance of CN1 terminal sensor – (25°C / 5KΩ). For other resistance, please refer to the Temperature – Resistance Sheet. Resistance of CN2 terminal sensor – (25°C / 20KΩ). For other resistance, please refer to the Exhaust Temperature Sensor Resistance Sheet.	Replace the temperature sensor if the resistance is incurred to drift, open or short circuiting.	Photo 4
3	If the above testing is normal	Outdoor power source board	



(4) Display E4

Symptom		Display E4	
Cause		System abnormal: Let the compressor run for 5 minutes. If the indoor coil temperature cannot be 2°C lower than that before the compressor is started (2°C higher for heating mode), it can be judged that the system is abnormal.	
S/N	Inspections	How to Solve	Remarks
1	Check the high-pressure and low-pressure valves.	If not open, open again to ensure the system circulation is smooth.	Photo 5
2	Check the system refrigerant (Start and run under cooling mode. When the compressor is started, check the outlet temperature for its change. If the change is not obvious after 5 minutes)	The system is in shortage of refrigerant. Test with pressure gauge, check the leakage point and recharge the refrigerant.	Photo 6
3	Check the evaporator coil temperature sensor (25°C/5KΩ). For other resistance, please refer to the Temperature – Resistance Sheet.	Replace the temperature sensor if the resistance is incurred to drift, open or short circuiting.	Photo 7
4	The above inspections are normal	1. The flow might be uneven for indoor system. Short circuit JP4 jumper of the indoor control board to shield this protection function (V1 – Indoor Main PCB).	Photo 8
		2. The flow might be uneven for indoor system. Dial the JP4 switch of the outdoor power source board to position “1” to shield this protection function (V4 – Power Source Board).	Photo 9
		Replace the indoor main PCB if the problem cannot be solved by using the above methods.	

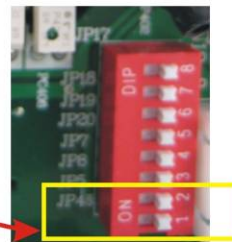
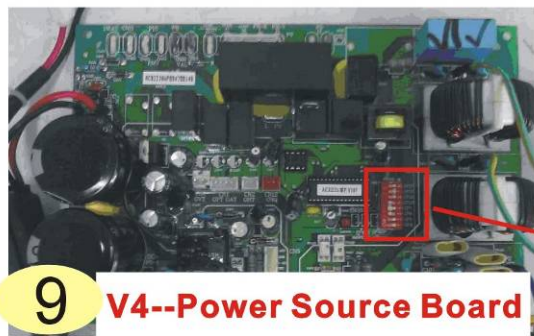
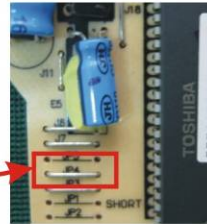
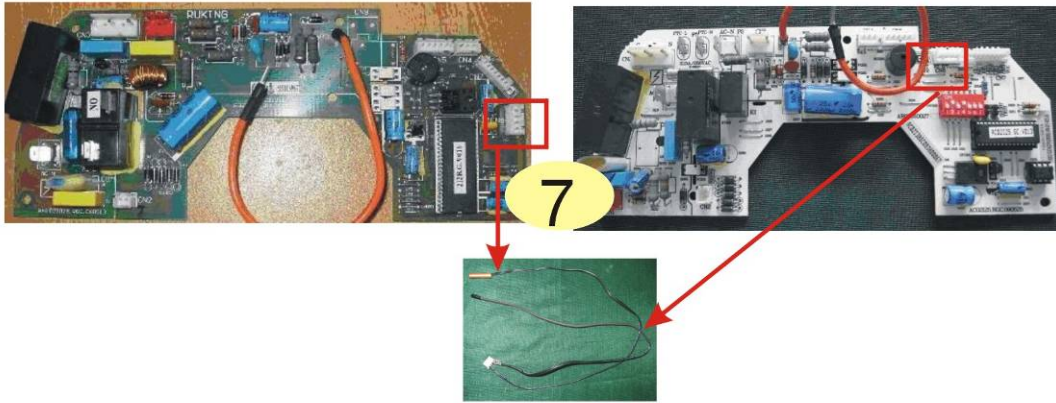

(5) Display EC

Symptom		Display EC			
Cause		Outdoor communication fault between power source board and intelligent power module			
S/N	Inspections	How to Solve		Remarks	
1	Check the contact of communication wire (CN5) between power source board and intelligent power module	Insert again if loose.		Yellow-line part	
2	After the complete unit is energized, check the indicators on outdoor power source board and intelligent power module	The indicator on power source board blinks normal (bright for 1 second and dark for 1 second), but the indicator on intelligent power module does not work normally	Replace the intelligent power module	If the fault remains unsolved, replace the power source board again.	Red-line part
		The indicator on intelligent power module blinks normal (bright for 1 second and dark for 1 second), but the indicator on power source board does not work normally	Replace the power source board	If the fault remains unsolved, replace the intelligent power module again.	Orange-line part
		VP1	Replace power source board	If the fault remains unsolved, replace the intelligent power module again.	

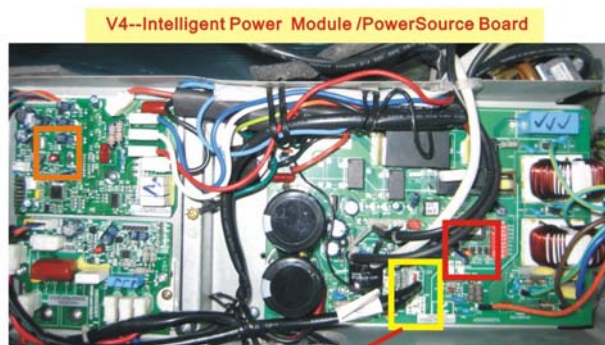
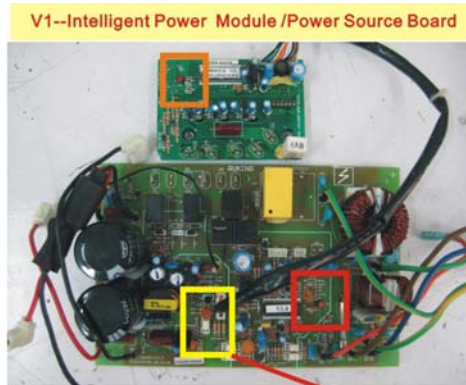

CN5 position and marking

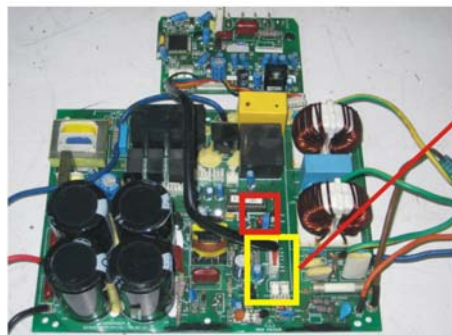

(6) Display EP

Symptom		Display EP	
Cause		Temperature switch fault (on top of the compressor)	
S/N	Inspections	How to Solve	Remarks
1	Check the insert position CN3 of the compressor top temperature switch wires on outdoor power source board	Insert again if loose.	Photo 10
	No switch on compressor top	Jumper short-circuiting (This function not provided for 1 – 1.5P unit)	
2	Compressor temperature. The temperature is very high, accompanied with bad smell.	Check the U, V and W wires of the compressor.	Photo 11
		Check the system pressure.	Photo 12
		Check the outdoor ventilation and if there is any obstruction that affects the normal radiating of the air conditioner.	
3	Compressor temperature: The temperature is not high. Short circuit CN3.	If the fault is solved after short circuiting, replace the shell temperature switch.	
		If the fault remains unsolved after replacing the shell temperature switch, please replace the outdoor power source board.	

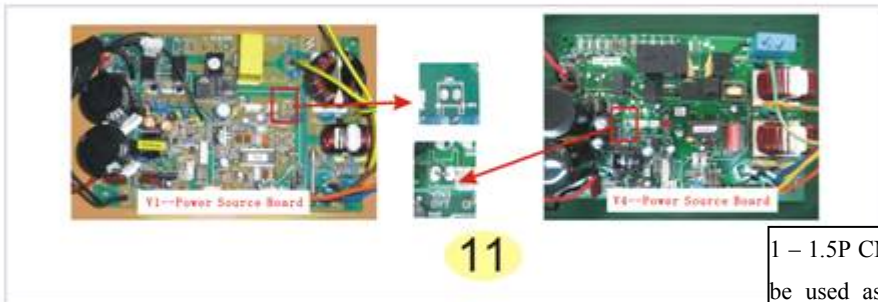
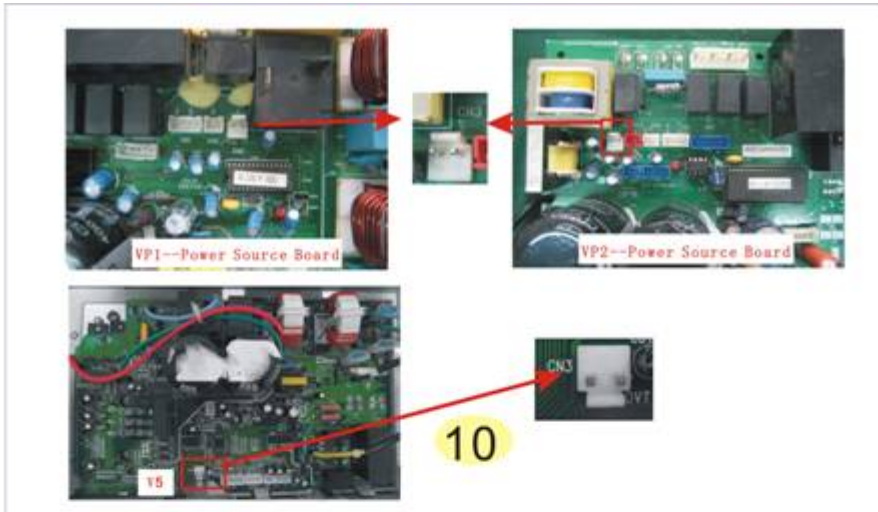

1 – 1.5P CN3 jumper. The jumper may be used as alternative if there is no compressor top switch.

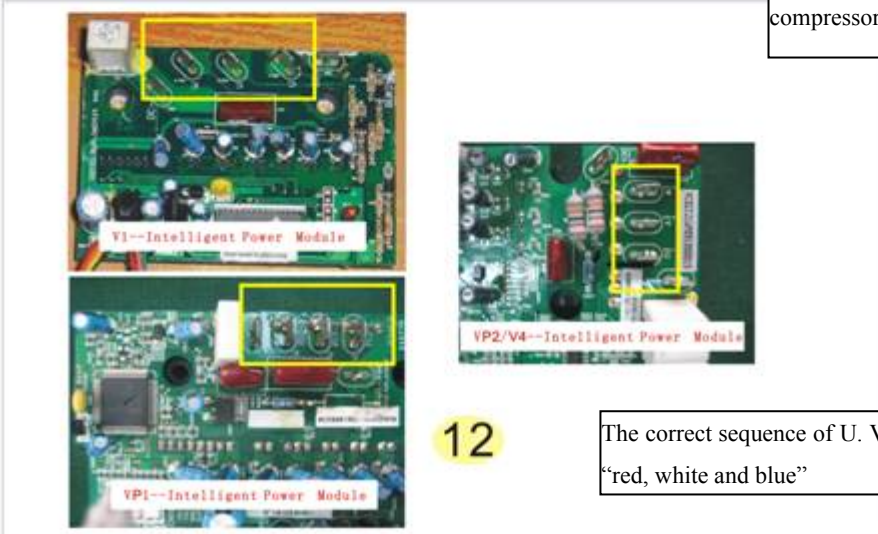

The correct sequence of U, V and W wiring shall be “red, white and blue”

(7) Display EA

Symptom		Display EA	
Cause		Current sensor fault	
S/N	Inspections	How to Solve	Remarks
1	Check for refrigerant leakage	Find the leakage point and recharge the refrigerant	
2	V1 inverter unit : Test the voltage of 5# pin to 2# pin on power factor correction	If higher than 0.4V, replace the intelligent power module	Photo 13
		If not higher than 0.4V, replace power factor correction	
3	V2、V3、V4、V5、VP1、VP2 inverter unit	Replace the outdoor power source board	

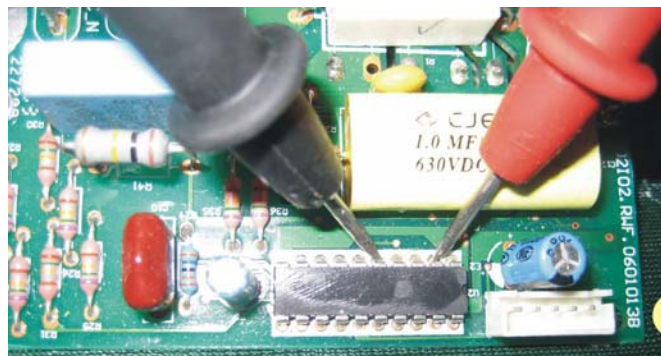

(8) Display EU

Symptom		Display EU	
Cause		Voltage sensor fault	
S/N	Inspections	How to Solve	Remarks
1	V1 inverter unit: Communication wires between outdoor power source board and intelligent power module (CN5)	Insert again if loose.	Photo 14
		If the fault remains unsolved after connection again, please replace the outdoor power source board.	
		If the fault remains unsolved after replacement of outdoor power source board, please replace the intelligent power module.	
2	V2、V3、V4、V5、VP1、VP2 Inverter Unit	Replace the outdoor power source board	

V1--Intelligent Power Module / Power Source Board

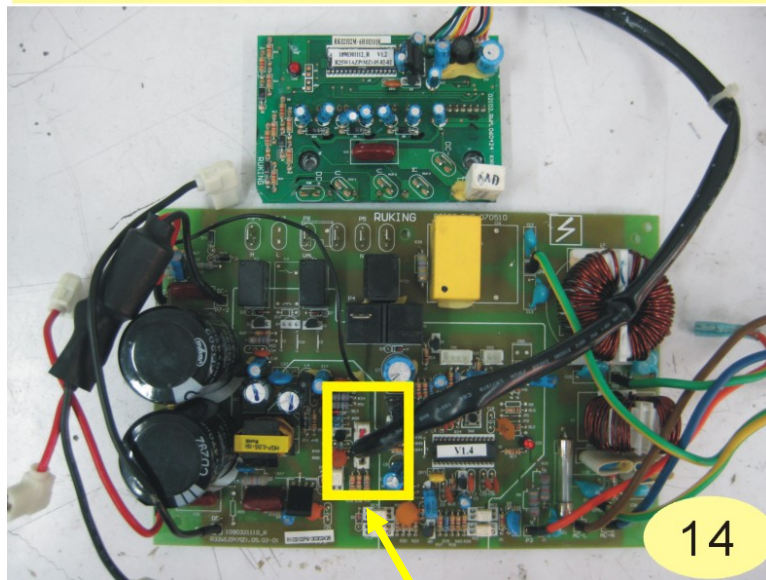

Check CN5 insert.

(9) Display E9 (Firstly display P0 or P9, then change to E9)

Symptom		Display E9 (Firstly display P0 or P9, then change to E9)			
Cause		Intelligent power module of drive and module fault			
S/N	Inspections		How to Solve	Remarks	
1	Re-energize and check the protection code on display. Firstly display P0	If this code is displayed when the compressor is started for several seconds or even not started, check the compressor connection for correctness		If no insert wrong, replace the intelligent power module	Photo 15
		“P0” appears when the air conditioner is working	Check if the outdoor module is tightly installed onto the radiating fins and if the silicone is applied evenly	Fix the screws again if loose.	Photo 16
			Check the system pressure.	Recharge refrigerant if the pressure is low. Discharge some refrigerant if the pressure is too high.	
			Check the outdoor ventilation and if there is any obstruction that affects the normal radiating of the air conditioner.	Install to the position as required in the Instruction Manual and ensure the air inlet and outlet of the outdoor unit is smooth.	
			The above inspections are normal, but the fault remains unsolved	Replace the intelligent power module	
2	Re-energize and check the protection code on display. Firstly display P9	If this code is displayed when the compressor is started for several seconds or even not started, check the compressor connection for correctness		If no insert wrong, replace the intelligent power module	
		P9 appears after the air conditioner is started and has run for a period of time	Cooling / heating is normal during run	Replace the intelligent power module	
			If the cooling / heating is abnormal, check the compressor wiring for correctness.	Insert again if loose.	Be sure to apply silicone when replacing intelligent power module.
		When the compressor is restarted immediately after stop, this might also cause P9 protection because the cooling system is not stable.		Try starting the air conditioner again after a longer period of stop	

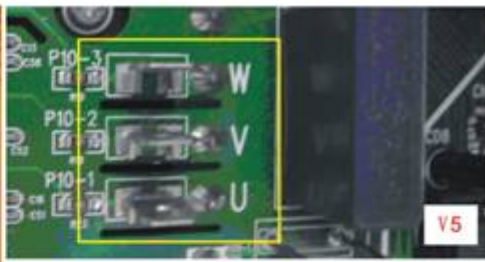

15

The wires on U, V and W ends are respectively colored "red, white and blue".

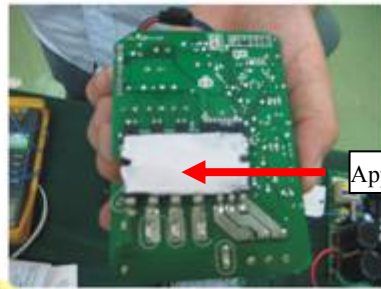
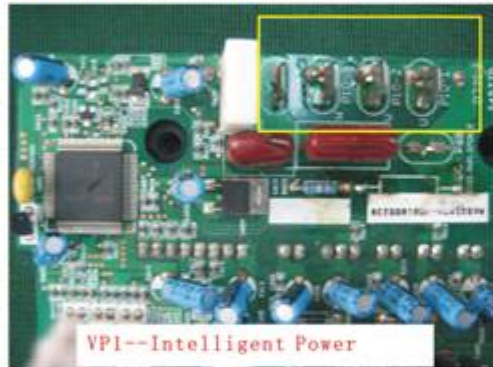

16

If the screw is not fixed tightly to position, it is easy to cause poor radiation and damage to the elements.

(10) Display E0、E5

Symptom		Display E0、E5			
Cause		Indoor / outdoor communication fault			
S/N	Inspections	How to Solve	Remarks		
1	Energize and observe for approx. 10 minutes. If E0 is always displayed or changed to E5 after a period of time:	1. Check if the indoor and outdoor connections are correct. The terminal L and N shall correspond to each other on indoor and outdoor units. Measure the voltage on outdoor terminal L and N (before display of E0 fault). If the voltage is “0”:	Replace the indoor control board.	Photo 17 (red)	
		2. If the L & N voltage is normal, measure the voltage between the outdoor terminal N and 1. If the voltage change occurs between 0~24V (change pulse voltage)	Replace the indoor main PCB.	Photo 17 (yellow)	
		3. If the L & N voltage is normal, measure the voltage between the outdoor terminal N and 1. If the voltage change occurs between 0~12V(change pulse voltage), but there is no 24V:	Replace the outdoor power source board		
		4. If the L & N voltage is normal, measure the voltage between the outdoor terminal N and 1. If the voltage has no change:	Firstly replace the indoor main PCB. If the fault remains unsolved, replace the outdoor power source board.		
		5. Indicator on outdoor power source board	1) The indicator is dark: Check PFC board – Test the pins of rectifier bridge, fast recovery diode (FRD) and IGBT elements for any breakdown, short circuiting or damage.	If damaged, it is needed to replace PFC board.	Photo 17 (red)
			2) If no damage, test the DC voltage between DC+ and DC-. If the voltage is approx. 300V:	Replace the power source board.	Photo 18 (yellow)
			3) If no damage, test the DC voltage between DC+ and DC-. If the voltage is zero:	Replace the power factor correction.	
		6. If the problem cannot be solved by using the methods above:	Firstly replace the intelligent power module . If the problem remains unsolved, replace the indoor main PCB. Power source board . power factor correction.		
7. If this fault appears at the initial installation and testing of the complete unit, please check if the indoor control board and outdoor inverter module are of the same generation.	Replace with the same generation of products				

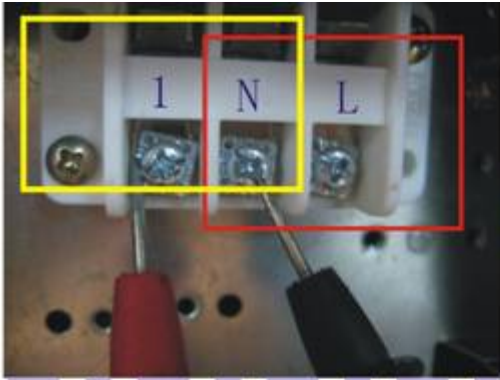

17

V1--Power Factor



V4--Power Factor

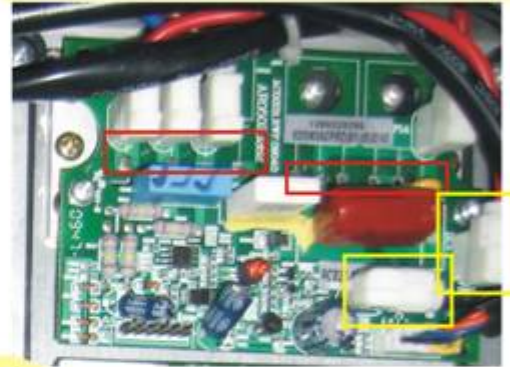

18

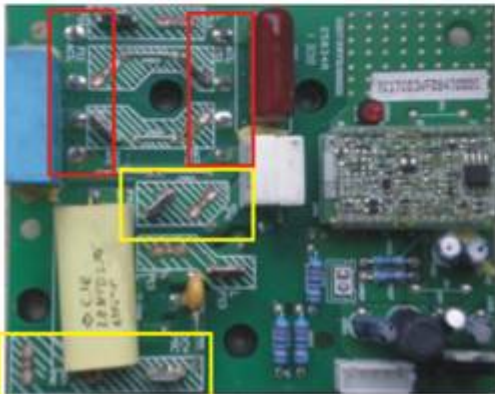

VP2--Power Factor

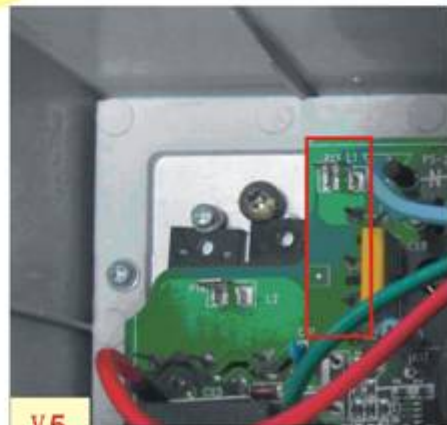

V5

Test the DC voltage between DC+ and DC-.

Check **power factor correction**– Test the pins of rectifier bridge, fast recovery diode (FRD) and IGBT elements for any breakdown, short circuiting or damage.

(11) Display EE

Symptom		Display EE	
Cause		EEPROM fault	
S/N	Inspections	How to Solve	Remarks
1	Shut down the power supply and re-energize. If the fault remains, it is needed to check if the indoor EEPROM installation is loose or improper.	Fix again	Photo 19
	Shut down the power supply and re-energize. If the fault remains, it is needed to check if the outdoor EEPROM installation is loose or improper.	Fix again	Photo 20
2	If the installation is good:	Replace the indoor main PCB firstly	
3	If the fault remains unsolved after replacement of the indoor control board:	Outdoor power source board	



(12) Display P0

Symptom		Display P0		
Cause		Variable-frequency drive		
Inspections		How to Solve	Remarks	
Re-energize and check the protection code on display. Firstly display P0	If this code is displayed when the compressor is started for several seconds or even not started, check the compressor connection for correctness.	If no insert wrong, replace the intelligent power module	Photo 22	
	“P0” appears when the air conditioner is working	Check if the outdoor intelligent power module is tightly installed onto the radiating fins and if the silicone is applied evenly.	Fix the radiator again if loose.	Photo 23
		Check the system pressure.	Recharge refrigerant if the pressure is low. Discharge some refrigerant if the pressure is too high.	
		Check the outdoor ventilation and if there is any obstruction that affects the normal radiating of the air conditioner.	Install to the position as required in the Instruction Manual and ensure the air inlet and outlet of the outdoor unit is smooth.	
		The above inspections are normal, but the fault remains unsolved	Replace the intelligent power module	

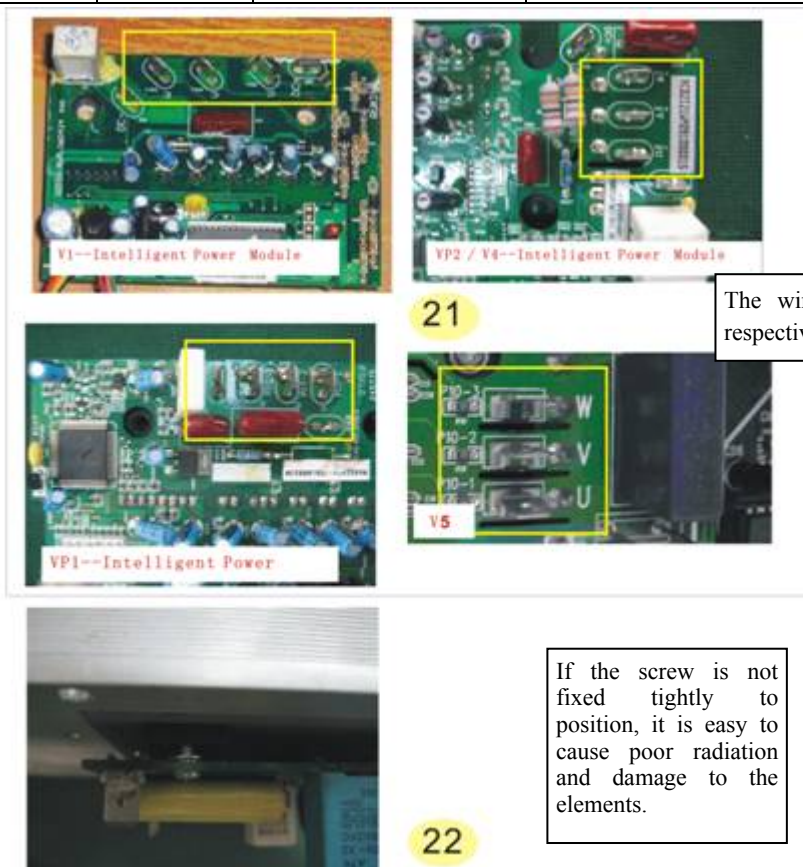

The wires on U, V and W ends are respectively colored “red, white and blue”.

If the screw is not fixed tightly to position, it is easy to cause poor radiation and damage to the elements.

(13) Display P1

Symptom		Display P1	
Cause		Overvoltage / undervoltage protection	
S/N	Inspections	How to Solve	Remarks
1	Test the supply voltage if it is between 160V ~260V (AC) .	It is normal protection if exceeding this range.	
2	Test if the voltage between L and N terminal of outdoor unit is within 160V~260V (AC) .	It is normal protection if exceeding this range.	Photo 24
3	If the voltage is normal:	Replace the outdoor power source board	

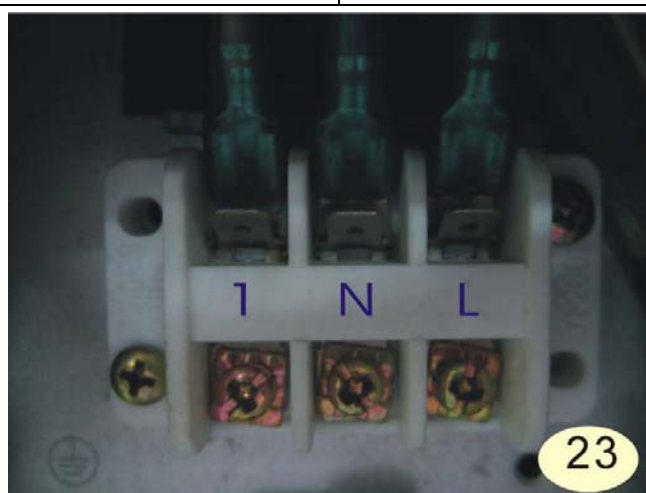

(14) Display P2

Symptom		Display P2	
Cause		Overcurrent protection	
S/N	Inspections	How to Solve	Remarks
1	Check if the outdoor fan motor is stopped due to overheat protection, or damaged, and if the fan capacitor is damaged.	Replace the damaged capacitor and the damaged outdoor fan motor.	
2	power source board or intelligent power module damaged	VP1-- Replace the power source board V1-- Replace the intelligent power module. V4 and VP2-- Replace the intelligent power module.	

(15) Display P4

Symptom		Display P4	
Cause		Exhaust overtemperature protection	
S/N	Inspections	How to Solve	Remarks
1	Check if the air inlet and outlet of outdoor unit is blocked by any obstructions.	Install to the position as required in the Instruction Manual and ensure the air inlet and outlet of the outdoor unit is smooth.	
2	Check the system for shortage of refrigerant.	Add refrigerant	
3	Check if the exhaust temperature sensor is drifted, short circuited or open circuited. (25°C/20KΩ). For other resistances, please refer to the Exhaust Temperature Sensor – Resistance Sheet)	Replace the exhaust temperature sensor	Photo 24
4	Control board damaged	Replace the outdoor power source board	



24

(16) Display P5

Symptom		Display P5	
Cause		Subcooling protection under cooling mode	
S/N	Inspections	How to Solve	Remarks
1	Check if the air inlet and outlet of indoor unit is blocked by any obstructions.	Install to the position as required in the Instruction Manual and ensure the air inlet and outlet of the outdoor unit is smooth.	
2	Check the system for shortage of refrigerant.	Add refrigerant	
3	Check if the exhaust temperature sensor is drifted, short circuited or open circuited. (Measure the resistance of the resistors on two ends of indoor temperature sensor: (25°C / 5KΩ). For other resistances, please refer to the Temperature – Resistance Sheet (Appendix 1).	Replace room temperature sensor (IRT) and Indoor pipe (coil) temperature sensor (IPT)	Photo 25
4	Control board damaged	Replace the indoor control board	

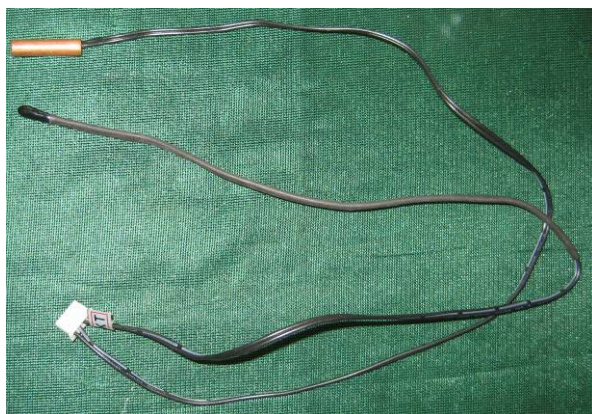

25

(17) Display P6

Symptom		Display P6	
Cause		Overheating protection under cooling mode	
S/N	Inspections	How to Solve	Remarks
1	Check if the air inlet and outlet of outdoor unit is blocked by any obstructions.	Install to the position as required in the Instruction Manual and ensure the air inlet and outlet of the outdoor unit is smooth.	
2	Check the system for shortage of refrigerant.	Add refrigerant	
3	Check if the outdoor evaporator coil temperature sensor is drifted, short circuited or open circuited (25°C/5KΩ). For other resistance, please refer to the Temperature – Resistance Sheet.	Replace the outdoor coil temperature sensor	Photo 26
4	Control board damaged	Replace the outdoor power source board	

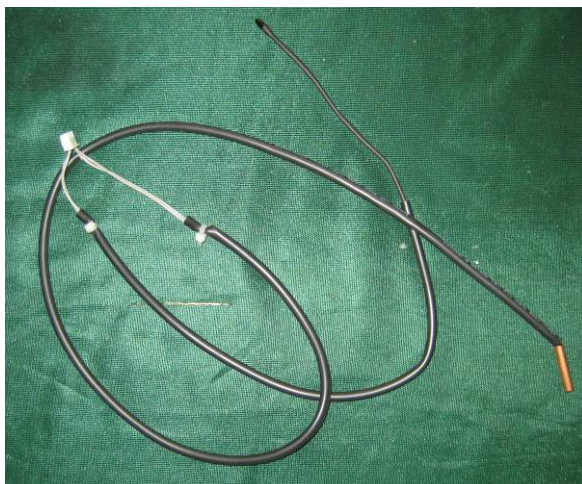

26

(18) Display P7

Symptom		Display P7	
Cause		Overheating protection under heating mode	
S/N	Inspections	How to Solve	Remarks
1	Check if the air inlet and outlet of outdoor unit is blocked by any obstructions.	Install to the position as required in the Instruction Manual and ensure the air inlet and outlet of the outdoor unit is smooth.	
2	Check the system for shortage of refrigerant.	Add refrigerant	
3	Check if the exhaust temperature sensor is drifted, short circuited or open circuited. (Measure the resistance of the resistors on two ends of indoor temperature sensor: (25°C / 5KΩ). For other resistances, please refer to the Temperature – Resistance Sheet (Appendix 1).	Replace the Room temperature sensor(IRT) and Indoor pipe(coil) temperature sensor(IPT)	Photo 27
4	Control board damaged	Replace the indoor control board	

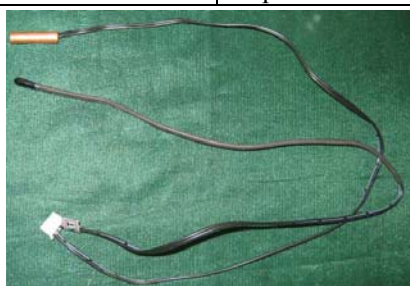

27

(19) Display P8

Symptom		Display P8	
Cause		Outdoor overtemperature / undertemperature protection	
S/N	Inspections	How to Solve	Remarks
1	The compressor cannot run under cooling mode when the outdoor temperature is lower than -1°C, or run under heating mode when the outdoor temperature is higher than 33°C, whilst the compressor alarms P8 protection.	Normal protection function	
2	If the temperature is not within the protective range above, please refer to the Temperature – Resistance Sheet (See Appendix). Use the multimeter to measure the resistors on the two ends of outdoor intake temperature sensor (CN1) (25°C/5KΩ). For other resistance, please refer to the Temperature – Resistance Sheet.	Replace the sensor if it is incurred to drift, open circuiting or short circuiting.	Photo 28
3	If the fault remains unsolved after replacement of the sensor	Replace the outdoor power source board	

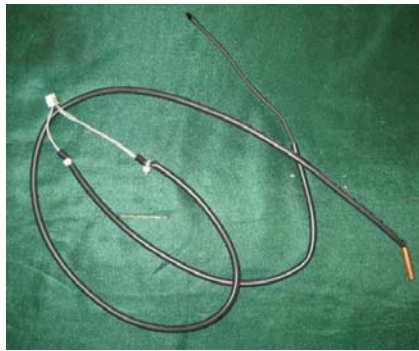

28

(20) Display P9

Symptom		Cause		Display E9 (Firstly display P0 or P9, then change to E9)	
Cause		Intelligent power module of drive and module fault			
S/N	Inspections		How to Solve	Remarks	
1	Re-energize and check the protection code on display. Firstly display P9	If this code is displayed when the compressor is started for several seconds or even not started, check the compressor connection for correctness.		If no insert wrong, replace the intelligent power module.	Photo 29
		P9 appears after the air conditioner is started and has run for a period of time	Cooling/heating is normal during run	Replace the intelligent power module.(Be sure to apply silicone when replacing the intelligent power module.).	Photo 30
			If the cooling / heating are abnormal, check the compressor wiring for correctness.	Insert again if loose	
		When the compressor is restarted immediately after stop, this might also cause P9 protection because the cooling system is not stable.		Try starting the air conditioner again after a longer period of stop	

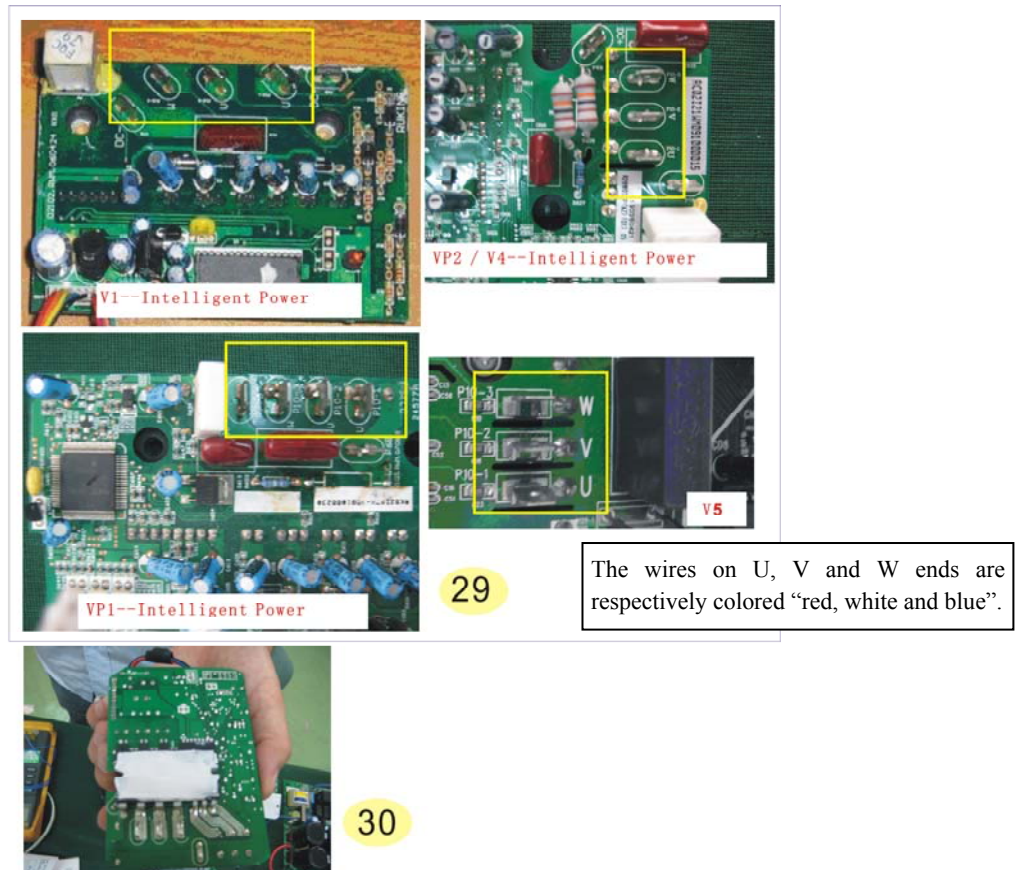

2. Other faults

1) The indoor unit works normally but the outdoor unit does not work.

Cause Analysis:

- a) If fault code is displayed: If yes, treat according to fault code. If no, check according to the following steps.
- b) If the outdoor fan runs normally (The outdoor fan is started 5 seconds before the compressor is started, and it is stopped 15 seconds after the compressor is stopped), the client might make wrong judgment on that the outdoor unit does not work because the compressor working frequency is low or the system is in shortage of refrigerant. Check the system cooling / heating effect and confirm if the system is in shortage of refrigerant.
- c) Check if the resistance of each temperature sensor is drifted (See appendix for the temperature sensor parameters): If yes, replace the temperature sensor.
- d) Check if the JP3 jumper of indoor control board is soldered. If not, solder the jumper. Then restart the unit and check what protection code will be displayed. Treat according to the fault code.
- e) Check if the indoor / outdoor and circuit board wiring. Check if the connection is secure. Please tighten the wires.

2) The outdoor unit is stopped when the air conditioner has run for a period of time

Cause Analysis:

- a) If any fault is displayed after stop: If yes, treat according to fault code. If not, check according to Step (b).
- b) Check if the supply voltage is normal, including the voltage change when the air condition is

started. If the voltage is unstable or changes too heavily, please check the power source. If no problem, check according to Step (c).

- c) Check if the temperature sensors are normal (See appendix for the temperature sensor parameters). Check if the resistance is drifted, open circuited or short circuited. If yes, replace the sensor. If normal, check according to Step (d).
 - d) Check if the indoor / outdoor circuit connection and power connection are in good contact. If no, tighten the connection wires. If yes, check according to Step (e).
 - e) Check if the JP3 jumper of indoor control board is soldered. If not, solder the jumper. Then restart the unit and check what protection code will be displayed. Treat according to the fault code.
 - f) Check if the refrigerant is too much or too less. If yes, add refrigerant.
- 3) The air conditioner is tripped when it is started.

Cause Analysis:

- a) Check if the user's power source plug is correctly connected (for example, the ground wire might be wrongly connected as the neutral wire)
 - b) Check if the indoor / outdoor circuit and the wiring terminal are correctly connected, and if there is short circuiting.
 - c) Check if the outdoor circuit board, wiring terminal and power connection wires are damaged, and if there is short circuiting to the metal parts.
 - d) Check if the rectifier bridge of outdoor controller (See appendix for its bridge) is short circuited (The short circuiting of rectifier bridge will probably cause tripping error).
- 4) The complete unit does not work

Cause Analysis:

- a) If fault code is displayed: If yes, treat according to fault code. If no, check according to Step (2).
- b) Check if the power plug is electrified. If no, check the power source. If yes, check if the controller fuse is good.. If no, replace the fuse. If yes, check according to Step (3).
- c) Check if the resistance of the sensors on indoor and outdoor units is drifted. If yes, replace the sensor. If no, check according to Step (4).
- d) Check if the indoor and outdoor communication is failed. The step is same as that for check when the indoor unit works normally but the outdoor unit does not work.

Appendix 1

1. Indoor main PCB:

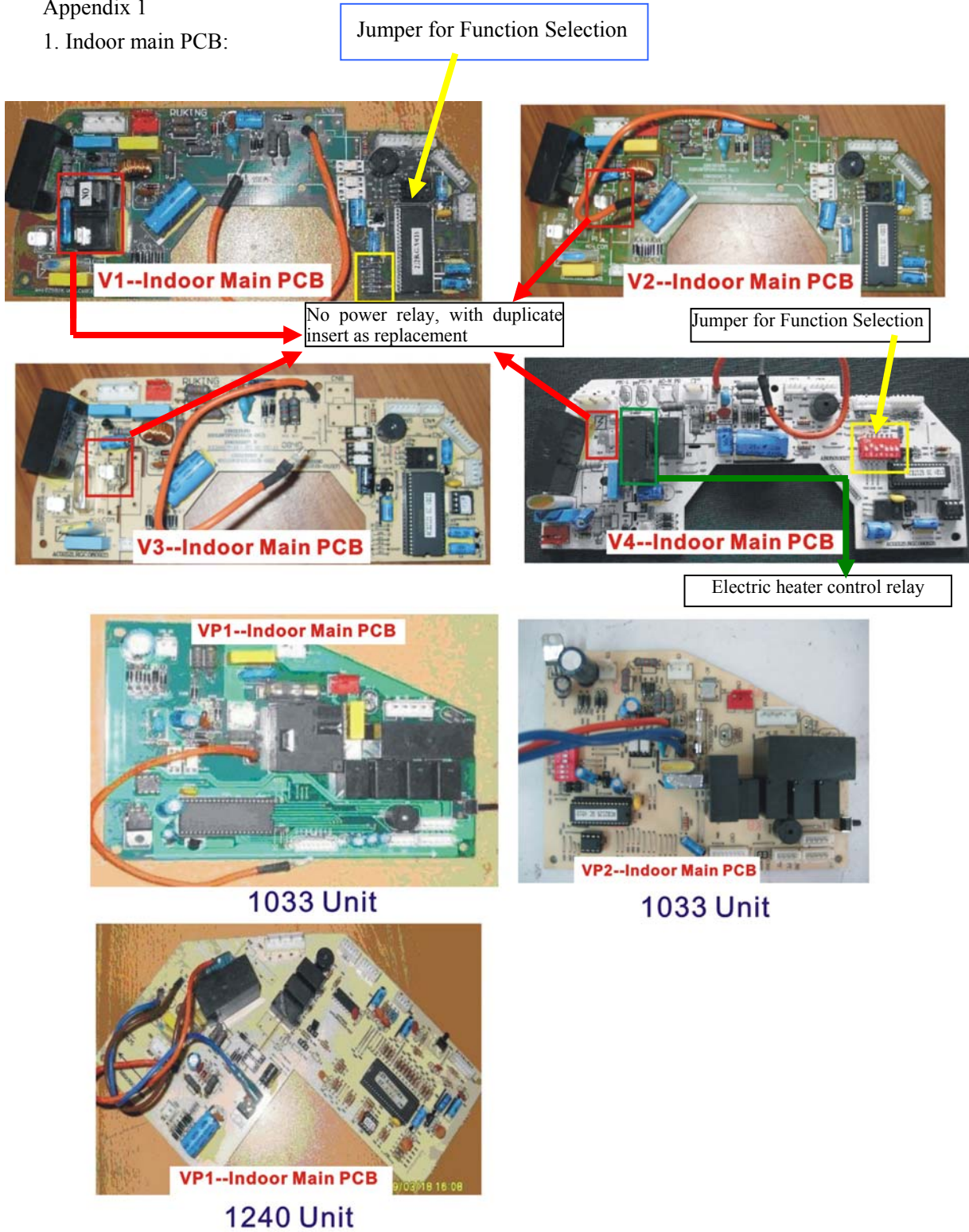

Indoor board for BL floor-standing inverter unit (display board + power drive board)

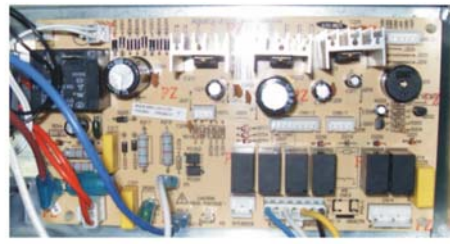

2. Outdoor power source board

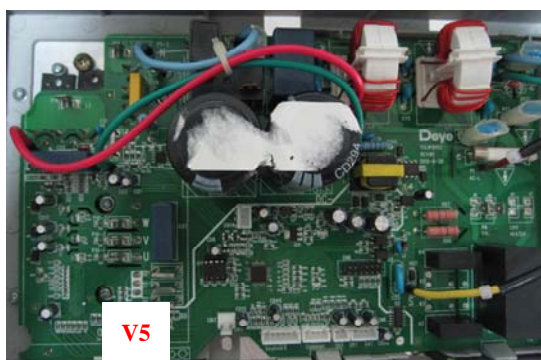
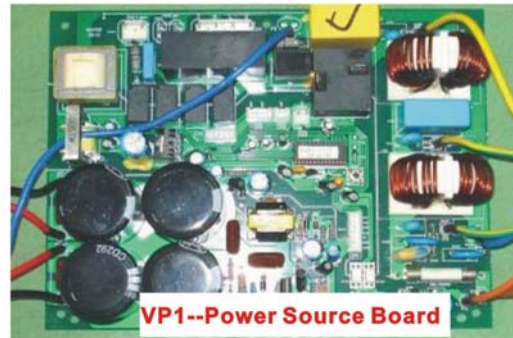
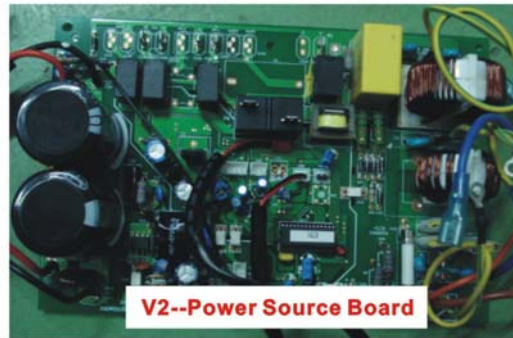
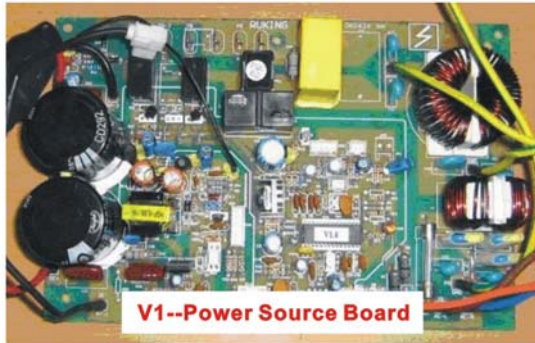

3. Power factor correction

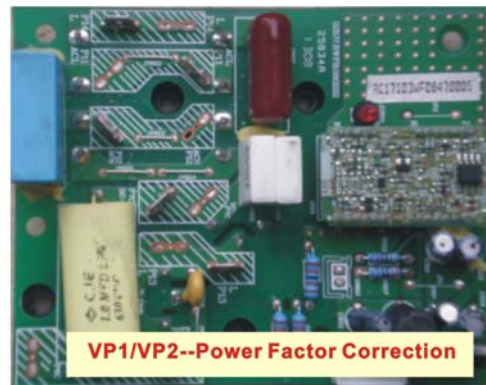
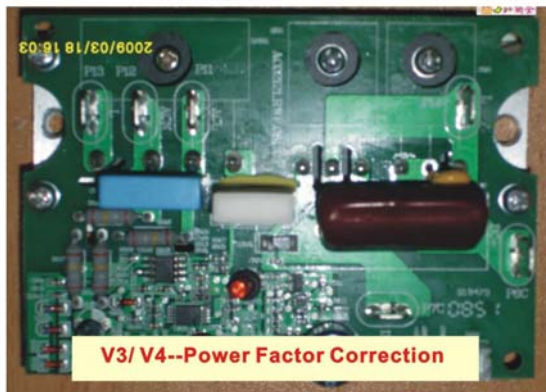
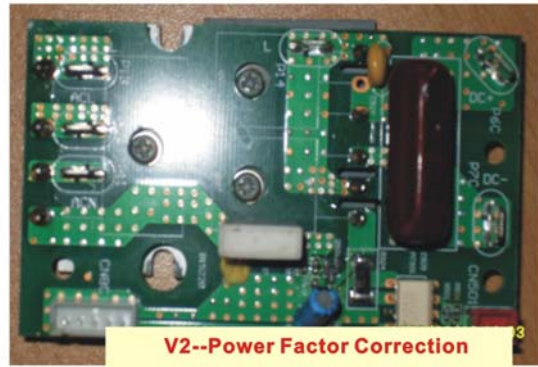
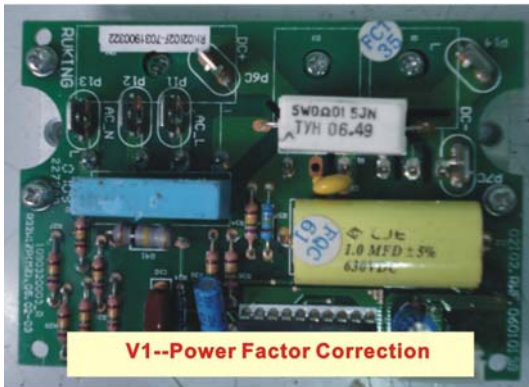

4. Intelligent power module:



Appendix 2

R25°C=5K Ω ±2%				B25°C/50°C=3470±2%				
TEMP.	R(Kohm)	Sensor Voltage on two ends	TEMP	R(Kohm)	Sensor Voltage on two ends	TEMP	R(Kohm)	Sensor Voltage on two ends
-25	48.488	4.524	17	6.863	2.868	59	1.512	1.143
-24	45.985	4.501	18	6.591	2.819	60	1.464	1.115
-23	43.627	4.477	19	6.332	2.769	61	1.418	1.088
-22	41.403	4.452	20	6.084	2.720	62	1.374	1.061
-21	39.305	4.426	21	5.847	2.671	63	1.331	1.035
-20	37.326	4.399	22	5.621	2.621	64	1.290	1.009
-19	35.458	4.371	23	5.404	2.572	65	1.250	0.984
-18	33.695	4.343	24	5.198	2.524	66	1.212	0.960
-17	32.030	4.313	25	5.000	2.475	67	1.175	0.936
-16	30.458	4.283	26	4.811	2.427	68	1.139	0.913
-15	28.972	4.252	27	4.630	2.379	69	1.105	0.890
-14	27.567	4.219	28	4.457	2.332	70	1.072	0.868
-13	26.239	4.186	29	4.292	2.285	71	1.040	0.847
-12	24.984	4.152	30	4.133	2.238	72	1.009	0.825
-11	23.795	4.117	31	3.981	2.192	73	0.979	0.805
-10	22.671	4.082	32	3.836	2.146	74	0.950	0.785
-9	21.606	4.045	33	3.697	2.101	75	0.922	0.765
-8	20.598	4.008	34	3.563	2.057	76	0.895	0.746
-7	19.644	3.969	35	3.435	2.012	77	0.869	0.728
-6	18.732	3.930	36	3.313	1.969	78	0.843	0.710
-5	17.881	3.890	37	3.195	1.926	79	0.819	0.692
-4	17.068	3.850	38	3.082	1.883	80	0.795	0.675
-3	16.297	3.808	39	2.974	1.842	81	0.773	0.658
-2	15.565	3.766	40	2.870	1.800	82	0.751	0.641
-1	14.871	3.723	41	2.770	1.760	83	0.729	0.625
0	14.212	3.680	42	2.674	1.720	84	0.709	0.610
1	13.586	3.635	43	2.583	1.681	85	0.689	0.595
2	12.991	3.590	44	2.494	1.642	86	0.669	0.580
3	12.426	3.545	45	2.410	1.604	87	0.651	0.566
4	11.889	3.499	46	2.328	1.567	88	0.633	0.552
5	11.378	3.452	47	2.250	1.530	89	0.615	0.538
6	10.893	3.406	48	2.174	1.495	90	0.598	0.525
7	10.431	3.358	49	2.102	1.459	91	0.582	0.512
8	9.991	3.310	50	2.032	1.425	92	0.566	0.499
9	9.573	3.262	51	1.965	1.391	93	0.550	0.487
10	9.174	3.214	52	1.901	1.357	94	0.535	0.475
11	8.795	3.165	53	1.839	1.325	95	0.521	0.463
12	8.433	3.116	54	1.779	1.293	96	0.507	0.452
13	8.089	3.067	55	1.721	1.262	97	0.493	0.441
14	7.760	3.017	56	1.666	1.231	98	0.480	0.430
15	7.447	2.968	57	1.613	1.201	99	0.467	0.419
16	7.148	2.918	58	1.561	1.172	100	0.455	0.409

Exhaust temperature sensor: R85°C=2. 113K Ω ± 3%

B25°C/85°C=4000 ± 2%

TEMP	Rmin	R(t)	Rmax	TEMP	Rmin	R(t)	Rmax	TEMP	Rmin	R(t)	Rmax
-30	283.3	322.9	367.7	24	19.36	20.89	22.52	78	2.563	2.654	2.745
-29	267.4	304.4	346.3	25	18.55	20	21.54	79	2.481	2.567	2.654
-28	252.5	287.1	307.4	26	17.77	19.14	20.6	80	2.402	2.484	2.567
-27	238.5	270.9	307.4	27	17.03	18.32	19.7	81	2.327	2.404	2.483
-26	225.4	255.7	289.8	28	16.32	17.55	18.85	82	2.254	2.327	2.401
-25	213.1	241.4	273.3	29	15.65	16.81	18.04	83	2.183	2.253	2.323
-24	201.5	228	257.9	30	15	16.1	17.27	84	2.115	2.182	2.248
-23	190.6	215.5	243.4	31	14.39	15.43	16.54	85	2.05	2.113	2.176
-22	180.3	203.6	229.8	32	13.81	14.79	15.34	86	1.985	2.047	2.109
-21	170.7	192.5	217	33	13.25	14.18	15.17	87	1.922	1.983	2.045
-20	161.6	182.1	205	34	12.72	13.6	14.54	88	1.861	1.922	1.983
-19	153.1	172.3	193.7	35	12.21	13.05	13.93	89	1.802	1.862	1.923
-18	145	163.1	183.2	36	11.72	12.52	13.36	90	1.746	1.805	1.865
-17	137.5	154.4	173.2	37	11.26	12.01	12.81	91	1.692	1.75	1.809
-16	130.3	146.2	163.9	38	10.82	11.53	12.29	92	1.639	1.697	1.755
-15	123.6	138.5	155.1	39	10.29	11.07	11.78	93	1.589	1.646	1.703
-14	117.3	131.3	146.8	40	9.986	10.63	11.31	94	1.54	1.596	1.653
-13	111.3	124.4	139	41	9.6	10.21	10.85	95	1.493	1.549	1.604
-12	105.6	118	131.7	42	9.231	9.813	10.42	96	1.448	1.502	1.558
-11	100.3	111.9	124.7	43	8.878	9.43	10	97	1.404	1.458	1.512
-10	95.24	106.2	118.2	44	8.54	9.064	9.612	98	1.362	1.415	1.469
-9	90.49	100.8	112.1	45	8.217	8.714	9.233	99	1.321	1.373	1.426
-8	85.99	95.68	106.3	46	7.908	8.38	8.872	100	1.284	1.335	1.387
-7	81.75	90.86	100.8	47	7.612	8.06	8.526	101	1.245	1.296	1.348
-6	77.74	86.31	95.74	48	7.328	7.754	8.196	102	1.209	1.258	1.309
-5	73.94	82.01	90.88	49	7.057	7.461	7.88	103	1.173	1.222	1.272
-4	70.35	77.95	86.29	50	6.797	7.18	7.578	104	1.139	1.187	1.236
-3	66.96	74.11	81.96	51	6.548	6.912	7.289	105	1.105	1.153	1.202
-2	63.74	70.48	77.87	52	6.309	6.655	7.013	106	1.073	1.12	1.168
-1	60.69	67.05	74	53	6.08	6.409	6.748	107	1.042	1.089	1.136
0	57.81	63.8	70.34	54	5.861	6.173	6.495	108	1.013	1.058	1.104
1	55.08	60.72	66.88	55	5.651	5.947	6.253	109	0.9833	1.028	1.074
2	52.49	57.81	63.61	56	5.449	5.73	6.02	110	0.9553	0.9997	1.045
3	50.03	55.05	60.52	57	5.255	5.522	5.798	111	0.9283	0.9719	1.016
4	47.71	52.44	57.59	58	5.07	5.323	5.585	112	0.9021	0.9451	0.9892
5	45.5	49.97	54.82	59	4.891	5.132	5.381	113	0.8765	0.9191	0.9626
6	43.41	47.62	52.2	60	4.72	4.949	5.101	114	0.8524	0.894	0.9367
7	41.42	45.4	49.71	61	4.556	4.774	4.997	115	0.8087	0.8595	0.9117
8	39.53	43.2	42.33	62	4.398	4.605	4.817	116	0.8059	0.8461	0.8875
9	37.74	41.29	45.12	63	4.247	4.448	4.644	117	0.7837	0.8233	0.8641
10	36.04	39.39	43.01	64	4.101	4.288	4.479	118	0.7623	0.8012	0.8413
11	34.42	37.59	41	65	3.961	4.139	4.32	119	0.7415	0.7798	0.8193
12	32.89	35.87	39.1	66	3.827	3.995	4.167	120			
13	31.43	34.25	37.29	67	3.698	3.858	4.021	121	0.702	0.7386	0.7773
14	30.04	32.71	35.58	68				122	0.6631	0.7195	0.7572
15	29.72	31.24	33.95	69				123	0.6649	0.7007	0.7378
16				70	3.339	3.476	3.616	124	0.6472	0.6824	0.7189
17				71	3.229	3.359	3.491	125	0.6301	0.6647	0.7006
18	25.13	27.26	29.55	72	3.122	3.246	3.372	126	0.6135	0.6476	0.6829
19	24.05	26.07	28.23	73	3.02	3.138	3.257	127	0.5974	0.6309	0.6657

20	23.02	24.93	26.97	74	2.921	3.033	3.146	128	0.5818	0.6148	0.649
21	22.04	23.84	25.77	75	2.827	2.933	3.04	129	0.5667	0.5991	0.6328
22	21.1	22.81	24.63	76	2.735	2.836	2.938	130	0.5521	0.5839	0.6171
23	20.21	21.83	23.55	77	2.647	2.743	2.84				

Appendix 3

Silk-printed label on outdoor control board of inverter unit

Control board connection	Connector label	Description label	Relay label	Remarks
AC power incoming wire L	P1	AC-L		
AC power incoming wire N	P2	AC-N		It is required to reserve 4 inserts at least
To indoor communication wire	P3	S		
Ground wire	P0	GND		
Outgoing wire L after filter	P4	L	K1	Relay control
Outgoing wire N after filter	P5	N		For multiple wires, use P5-1 and P5-2 to identify.
DC+ input	P6-1	DC+		
DC- input	P7-1	DC-		
DC+ output	P6-2	DC+		
DC- output	P7-2	DC-		
4-way valve output	P8	VAL	K4	
Outdoor fan HI output	P9-1	H	K2	
Outdoor fan LOW output	P9-2	L	K3	
Outdoor fan capacitor	P9-3	C		
Compressor output phase-U	P10-1	U		
Compressor output phase-V	P10-2	V		
Compressor output phase-W	P10-3	W		
Module DC+ input	P6B	DC+		Intelligent power module
Module DC- input	P7B	DC-		Intelligent power module
PFC board rectified input + (Direct-insert bridge AC input)	P11	DC+		Power factor correction
PFC board rectified input - (Direct-insert bridge AC input)	P12	DC-		Power factor correction
PFC inductance interface	P13、P14	L		Power factor correction
PFC DC+ output	P6C	DC+		Power factor correction
PFC DC- output	P7C	DC-		Power factor correction
Outdoor fan DC motor socket	CN9			
Outdoor temperature sensor	CN1			
Exhaust pipe temperature sensor	CN2			
Suction pipe temperature sensor	CN10			
Compressor top thermostat	CN3			

Switching power output of power source board	CN4			CN4B on Intelligent power module, and CN4C on Power factor correction
Communication signal of power source board and module board	CN5			CN5B on Intelligent power module
Electronic expansion valve control signal	CN6			CN6B on Intelligent power module
Electronic expansion valve socket	CN7			
Communication between power source board and PFC board	CN9			CN9C on Power factor correction
Communication between module board and PFC board	CN8B(Module board)			CN8B on Power factor correction
Base Auxiliary heating	CN11			

Cautions on Replacement of PCB Boards

1, Directive for Replacement of Inverter Module

When replacing Mitsubishi inverter module, the technician must take care on the operating process for replacement of inverter module. Special care shall be taken to ensure the coating quality of thermal grease. The detailed directive is as follows:

1. Before replacing the inverter module, make sure to eliminate the old thermal grease and foreign particles with soft clean cloth before you can apply the new thermal grease. Always use the thermal grease provided by the customer service department or the same silicone grease as used in the factory. Never use any other product of poor quality. Operate in strict accordance with the guideline.
2. Ensure that the thermal grease (silicone grease) is applied thin, flat and even. Use plastic scraper to apply the grease. Firstly, place a tiny quantity of thermal grease at the center of the place where the grease is to be coated. Then, use the plastic scraper to apply the grease at the center slightly and evenly onto the entire surface to be treated. In consideration of the deviation in the levelness of radiating fin, the thickness of thermal grease must be 0.1mm (for small area) to 0.3mm (for large area), depending on the size of radiating area.
Note: The function of thermal grease is to fill up the gap and let the surface tightly adhered. It is not true "the more the better".
3. Before placing the greased module flatly onto the radiating fin to tighten the screws, firstly hold down with the hands; then press and move back and forth slightly until it is in full contact before tightening the screws. When tightening the screws, take special care on the strength of radiator materials when using the electric screwdriver, torque screwdriver or torque wrench. Ensure that the screws are correctly tightened to position. The tightening force varies with the module.
4. Cautions on installation of screws on inverter module: If the tightening force is applied extremely unbalance'd during installation of the module onto the radiator, the silicon chip inside the module may be deformed due to the stress. And this might cause damage or degrade to the module. Therefore, be sure to operate according to the required tightening sequence.

The recommended tightening sequence for the inverter module fixed by two screws is as shown

below:

A\ Pre-tightening ①→②

B\ Final tightening ①→②

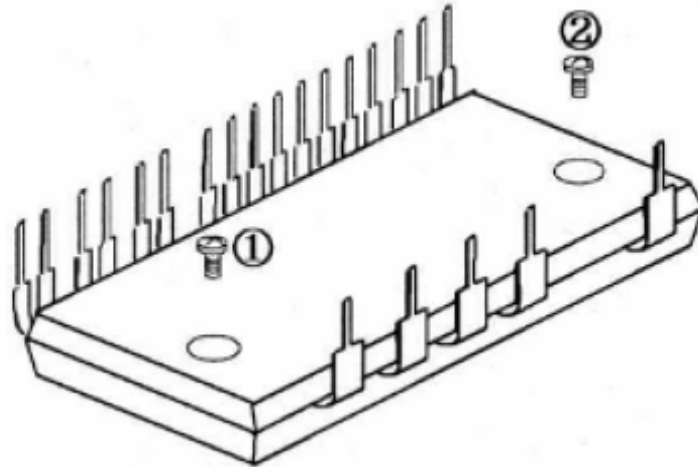
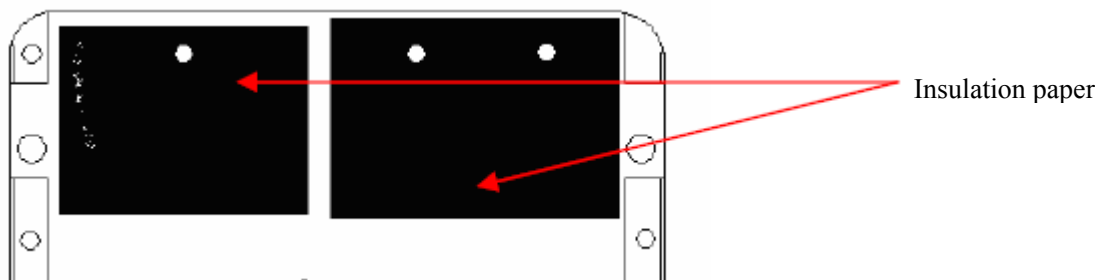

Figure Recommended Tightening Sequence for Screws

Other cautions: As the module is a precious and expensive element, never keep the new module close to magnetic object or touch the module with electrostatic object (including direct touch with your finger). Especially, touch with the port of signal terminal is easy to cause module internal breakdown and results in failure to use. If possible, you may wear electrostatic ring or glove.

2. Directive for Replacement of Power factor correction

- 1) Insulation paper must be attached between power diode, IGBT, rectifier and radiating fins. The screw locking torque is $7\pm 0.5\text{kgf.cm}$. Do not loosen the insulation paper after attaching it fully flat onto the radiator. To retighten after loosening, it is needed to eliminate the aluminum scraps on the radiator before retightening.



- 2) It is also needed apply the thermal grease evenly when replacing and installing the PFC with radiating substrate.

3. Directive for Replacement of Outdoor Power Source Board

- 1) The outdoor control is mostly the components carrying high current. The controller is designed of partial isolation and many circuits are commonly grounded with the high current. Take care on human safety.

- 2) As the high-current circuit is close to the light-current circuit, take care on the measuring position and safety problems during repair.
- 3) As there is large electrolytic capacitor on the outdoor power source board, plentiful residual electrons shall be discharged for a period of time after the power supply is cut off. In this case, please wait patiently until the capacitor is fully discharged before proceeding to further operation. Full discharge may take approx. 30 seconds. You may also connect a load (e.g. electric iron) between DC- and DC+ for manual discharge. After thorough discharge, use the multimeter RX10K to measure. The pointer shall point to "0" position and then slowly return to " ∞ ". If not, the electrolytic capacitor is damaged.
- 4) Make sure to have some understanding to the circuit before carrying out repair. Most fundamentally, the operator must know the composition of the circuits, position of each part and the possible function.
- 5) It is an extremely unscientific repair method for starting the measurement immediately after getting the circuit board, or directly energizing it to start the test. This will probably cause secondary damage to the repair board.
- 6) The indoor and outdoor wires must be kept in correct order. If not, it might cause failure and damage to the electric controller. When removing the screws, take protective measures to prevent the screws or other objects from falling down onto the circuit board or into the electric control box. If any, be sure to eliminate them on time.