

# Modification for LED Dash Turn Indicator using LDB1

(For TR6 and other makes/models with dash turn indicator wired across the switch)

There are a few challenges when replacing lamps with LEDs in your TR6. You may run into a couple of problems if you are trying to upgrade your dash turn indicator to an LED or you are replacing your exterior turn lamps with all LEDs and both left and right sides flash when turn switch is on. These problems are caused by lower current LED technology and Triumph wiring the dash indicator across the turn signal switch. See Fig. 1.

## Two common problems:

**1. Replacing Dash turn indicator** - Because LEDs are typically unidirectional, inserting an LED in the circuit of Fig. 1, the Dash indicator will only work in one direction. The fix is to use steering diodes to correct.

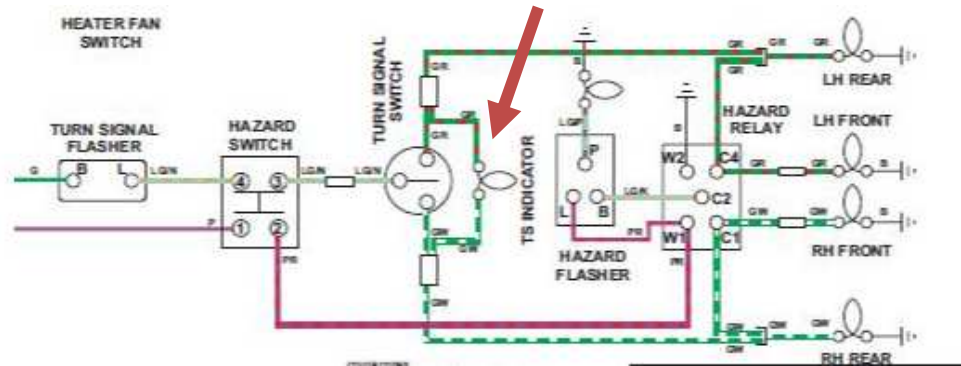

Figure 1 - Original wiring Early TR6

**2. Upgrading exterior turn lamps with LEDs** - when replacing turn lamps with LEDs, the filament turn indicator bulb is a short across the circuit so enabling the turn switch will likely turn on both left and right turn lamps. LED lamps are low current so it will only take a few hundred milliamps to turn them on. Use steering diodes to fix.

## Adding Steering diodes for LED TR6 turn signal indicator

A simple modification with steering diodes to correct the problem. Note the dash turn lamp socket has two wires, Green/Red and Green/White. The socket is isolated from ground with a plastic ring by the clip pins. The socket is first cut out of the circuit, the diode bridge black wires are connected as shown, the diode bridge red wire is connected to the socket Green/white wire and the Socket Green/Red wire is connected to ground

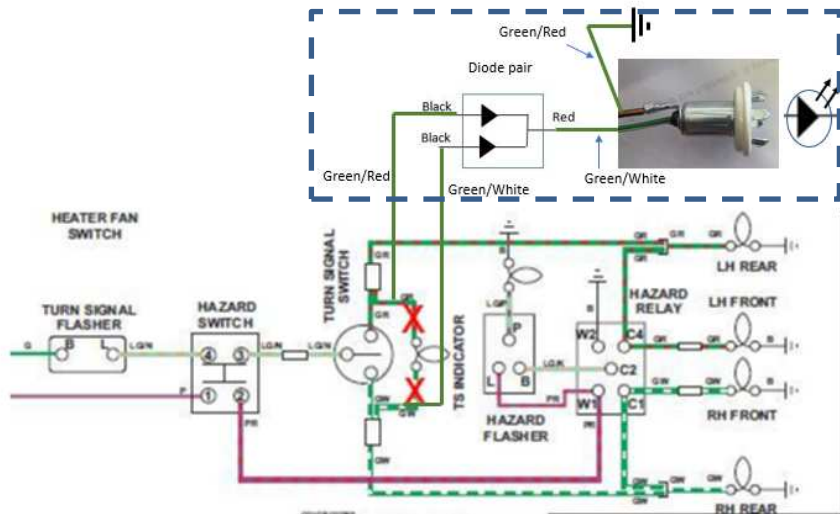

Figure 2 – Modified with steering diodes

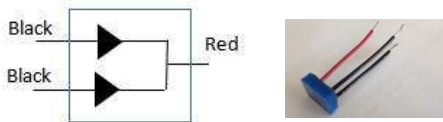

Fig. 3 Diode Bridge Schematic and physical part

## Procedure:

1. Disconnect power from the battery.
2. Locate Turn Signal indicator socket and pull out from speedometer Fig . 4



Fig. 4

3. Leaving a length of wire on socket, cut socket out. Fig. 5
4. Connect wires as shown (it doesn't matter which colored wire goes to the black wires on Diode). Fig. 6 to Fig. 7
5. Connect red wire of diode, Fig. 7, to wire going into center base of socket. (Note: This is typically the Green/White but it may be Green/Red).
6. Connect wire that goes to the outside body of the socket to the black supplied ground wire and ground. We suggest lug and screw on speedo or tach.

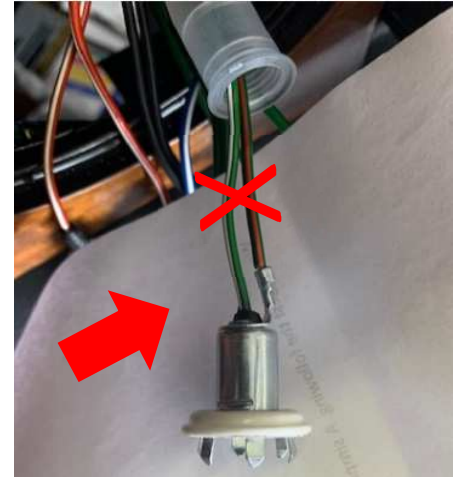

Fig 5

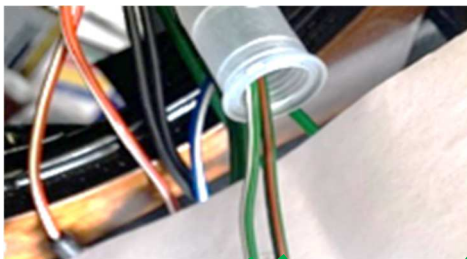

Fig 6

Green/White

Green/Red

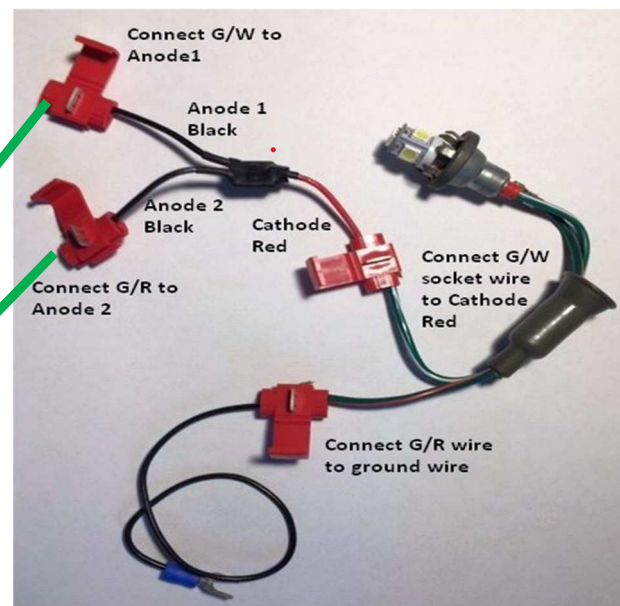

Fig 7

7. Reconnect battery and test.
8. Contact [sales@litezupp.com](mailto:sales@litezupp.com) if you have any questions.

Updated 2022\_1